

- *Single Inlet / Single Fan*



Single Inlet/Single Fan—Industrial Class Evaporative Cooling Equipment with Capacities of 6,000 CFM to 30,000 CFM and up to 1.5" ESP or higher if required

Why?

Cel-Air® units are high capacity, high efficiency evaporative cooling equipment. With 24 cataloged units and sizes ranging from 6,000 CFM to over 100,000 CFM, United Metal Products gives the engineer, contractor, or owner the choice and options they want.

Benefits:

- 24 cataloged sizes
- 2" double wall or single wall construction
- Galvanized, aluminum, stainless steel
- 6,000–100,000 CFM and above
- Evaporative cooling
- Forward curve, airfoil, or backward inclined wheels
- ETL labeling available
- Powder coated
- Stainless steel reservoir available

Applications:

- Aircraft hangars
- Clean room M.U.A.
- Data centers
- Food processing plants
- Gymnasiums
- Hospitals
- Kitchens
- Make up air requirement
- Manufacturing facilities
- Military bases
- Mining industry
- Municipalities
- Prisons
- Process cooling
- Schools
- Textile industries
- Turbine inlet cooling
- Waste water treatment facility
- Warehouses

Resources Available for This Product

- Catalog By Mail
- Catalog Online



United Metal Products

1920 E Encanto Drive Tempe, AZ 85281
T 480.968.9550
F 480.968.9555
www.unitedmetal.com



		SINGLE INLET / SINGLE FAN - EXTERNAL STATIC PRESSURE ("WG)												Power Requirements (at 460/3/60) *			
MODEL # Air Volume	WITHOUT FILTERS	0.25		0.50		0.75		1.00		1.25		1.50		1.75		MCA Amps	MOP Amps
	WITH FILTERS	0.00		0.25		0.50		0.75		1.00		1.25		1.50			
		FAN	HP	FAN	HP	FAN	HP	FAN	HP	FAN	HP	FAN	HP	FAN	HP		
CEL-ODO-12 6,000 cfm	DWDI FC	15/15	3	15/15	3	15/15	3	15/15	3	15/15	5	15/15	5	15/15	5	12	15
	DWDI BI	18	2	18	2	18	3	18	3	18	5	18	5	18	5	12	15
	DWDI AF	22	1.5	22	2	22	2	22	3	22	3	22	3	22	5	12	15
CEL-ODO-16 8,000 cfm	DWDI FC	15/15	5	15/15	5	15/15	7.5	15/15	7.5	15/15	7.5	15/15	7.5	15/15	7.5	16	20
	DWDI BI	22	2	22	3	22	3	22	5	22	5	22	5	22	5	12	15
	DWDI AF	25	2	25	3	25	3	25	3	25	5	25	5	25	5	12	15
CEL-ODO-20 10,000 cfm	DWDI FC	18/18	5	18/18	7.5	18/18	7.5	18/18	7.5	18/18	7.5	18/18	7.5	18/18	10	20	25
	DWDI BI	25	3	25	3	25	5	25	5	25	5	25	5	25	7.5	16	20
	DWDI AF					25	5	25	5	25	5	25	5	25	7.5	16	20
CEL-ODO-24 12,000 cfm	DWDI FC	18/18	10	18/18	10	18/18	10	18/18	10	18/18	10	18/18	15	18/18	15	29	30
	DWDI BI	25	5	25	5	25	5	25	5	25	7.5	25	7.5	25	7.5	16	20
	DWDI AF			28	5	28	5	28	5	28	7.5	28	7.5	28	7.5	16	20
CEL-ODO-30 15,000 cfm	DWDI FC	25/20	7.5	25/20	7.5	25/20	7.5	25/20	10	25/20	10	25/20	10	25/20	15	29	30
	DWDI BI	28	5	28	5	28	7.5	28	7.5	28	7.5	28	10	28	10	20	25
	DWDI AF					32	5	32	7.5	32	7.5	32	7.5	32	10	20	25
CEL-ODO-36 18,000 cfm	DWDI FC	25/25	7.5	25/25	10	25/25	10	25/25	10	25/25	15	25/25	15	25/25	15	29	30
	DWDI BI	32	5	32	7.5	32	7.5	32	7.5	32	10	32	10	32	10	20	25
	DWDI AF			36	5	36	7.5	36	7.5	36	7.5	36	10	36	10	20	25
CEL-ODO-42 21,000 cfm	DWDI FC	25/25	10	25/25	15	25/25	15	25/25	15	25/25	15	25/25	15	25/25	20	36	40
	DWDI BI	36	5	36	7.5	36	7.5	36	10	36	15	36	15	36	15	29	30
	DWDI AF			40	7.5	40	7.5	40	7.5	40	10	40	10	40	15	29	30
CEL-ODO-48 24,000 cfm	DWDI FC	28/28	10	28/28	15	28/28	15	28/28	15	28/28	15	28/28	20	28/28	20	36	40
	DWDI BI	36	7.5	36	7.5	36	10	36	10	36	15	36	15	36	15	29	30
	DWDI AF					40	7.5	40	10	40	10	40	15	40	15	29	30
CEL-ODO-54 27,000 cfm	DWDI FC	28/28	15	28/28	20	28/28	20	28/28	20	28/28	20	28/28	20	28/28	25	45	50
	DWDI BI	36	10	36	10	36	15	36	15	36	15	36	15	36	15	29	30
	DWDI AF							40	10	40	15	40	15	40	15	29	30
CEL-ODO-60 30,000 cfm	DWDI FC	32	15	32	15	32	20	32	20	32	20	32	20	32	25	45	50
	DWDI BI	40	10	40	15	40	15	40	15	40	15	40	15	40	20	36	40
	DWDI AF									40	15	40	15	40	20	36	40

- * Unit power requirements, dimensions and weights are given as a guide. They include down discharge AF fans and the largest motor HP shown. Motors are standard efficiency single speed ODP.
- * Different fan or motor types, fan orientation or motor position will effect dimensions and weights. Full details will be given with any quotation.
- * All these units can operate at higher static pressures with fan or motor changes. Please contact the factory with your requirements.
- * Data is based on the maximum output of each unit size. Intermediate volumes will be achieved by reducing the fan speed.
- * Data shown is based at sea level. HP and performance may be effected at high altitudes.
- * The filter is an option. When adding filters, add the filter pressure drop to the unit ESP and use that total to select the motor HP.
- * Please specify the fan discharge location (Up, Down or End) when ordering these units.



		SINGLE INLET / SINGLE FAN EVAPORATIVE COOLER DIMENSIONS - See Drawing										WEIGHTS	
MODEL # Air Volume	FAN QTY & TYPE	WIDTH	HEIGHT	LENGTH	A "	B "	C "	D "	E1 "	E2 "	F "	With Clean Filters Ship lb	Operate lb
CEL-ODO-12 6,000 cfm	DWDI FC	60	61	90	6	12.3	18.5	15.9	20.7	20.7	22.1	1,650	1,950
	DWDI BI	60	61	98	6	14.0	22.4	22.4	18.8	18.8	23.7	1,775	2,075
	DWDI AF	60	61	106	6	16.1	28.2	28.2	15.9	15.9	25.9	1,975	2,275
CEL-ODO-16 8,000 cfm	DWDI FC	65	71	95	6	12.3	18.5	15.9	23.2	23.2	22.1	1,975	2,300
	DWDI BI	65	71	106	6	16.1	28.2	28.2	18.4	18.4	25.9	2,200	2,500
	DWDI AF	65	71	111	6	17.8	31.5	31.5	16.7	16.7	27.5	2,300	2,625
CEL-ODO-20 10,000 cfm	DWDI FC	72	71	99	6	14.5	21.9	18.8	25.0	25.0	24.3	2,200	2,600
	DWDI BI	72	71	115	6	17.8	31.5	31.5	20.2	20.2	27.5	2,525	2,925
	DWDI AF	72	71	115	6	17.8	31.5	31.5	20.2	20.2	27.5	2,550	2,925
CEL-ODO-24 12,000 cfm	DWDI FC	84	73	104	6	14.5	21.9	18.8	31.0	31.0	24.3	2,550	3,000
	DWDI BI	84	73	115	6	17.8	31.5	31.5	26.2	26.2	27.5	2,800	3,275
	DWDI AF	84	73	121	6	19.7	35.4	35.4	24.3	24.3	29.4	2,950	3,400
CEL-ODO-30 15,000 cfm	DWDI FC	84	84	121	6	17.5	26.1	31.4	28.9	28.9	27.3	2,975	3,450
	DWDI BI	84	84	121	6	19.7	35.4	35.4	24.3	24.3	29.4	3,150	3,625
	DWDI AF	84	84	127	6	21.9	39.7	39.7	22.2	22.2	31.6	3,300	3,775
CEL-ODO-36 18,000 cfm	DWDI FC	89	96	121	6	17.5	31.3	31.4	28.9	28.9	27.3	3,275	3,775
	DWDI BI	89	96	127	6	21.9	39.7	39.7	24.7	24.7	31.6	3,575	4,075
	DWDI AF	89	96	134	6	24.1	44.5	44.5	22.3	22.3	33.9	3,800	4,300
CEL-ODO-42 21,000 cfm	DWDI FC	98	96	121	6	17.5	31.3	31.4	33.4	33.4	27.3	3,500	4,075
	DWDI BI	98	96	139	6	24.1	44.5	44.5	26.8	26.8	33.9	4,125	4,700
	DWDI AF	98	96	146	6	25.0	49.9	49.9	24.1	24.1	34.8	4,325	4,900
CEL-ODO-48 24,000 cfm	DWDI FC	108	96	126	6	19.3	34.3	34.3	36.9	36.9	29.1	3,775	4,450
	DWDI BI	108	96	139	6	24.1	44.5	44.5	31.8	31.8	33.9	4,325	4,975
	DWDI AF	108	96	146	6	25.0	49.9	49.9	29.1	29.1	34.8	4,550	5,225
CEL-ODO-54 27,000 cfm	DWDI FC	120	96	126	6	19.3	34.3	35.2	42.9	42.9	29.1	4,025	4,775
	DWDI BI	120	96	139	6	24.1	44.5	44.5	37.8	37.8	33.9	4,625	5,375
	DWDI AF	120	96	143	6	25.0	49.9	49.9	35.1	35.1	34.8	4,850	5,600
CEL-ODO-60 30,000 cfm	DWDI FC	132	96	132	6	21.9	39.7	39.7	46.2	46.2	31.6	4,600	5,425
	DWDI BI	132	96	146	6	25.0	49.9	49.9	41.1	41.1	37.8	5,325	6,150
	DWDI AF	132	96	146	6	25.0	49.9	49.9	41.1	41.1	34.8	5,350	6,150

* Unit height shown above includes the standing roof seam.

* Allow a minimum service clearance of 36" in front of all access doors and air inlet louvers.

* We recommend a minimum incoming water line pressure of 50 psi. Under no circumstances should the incoming water line pressure exceed 125psi.

* Standard Evaporative Media access panels require (2) persons to lift on units over 72" high. Consider upgrading to hinged access doors on tall units.

* Due to continued product development, all data is subject to change without notice. Full details will be provided with submittals.

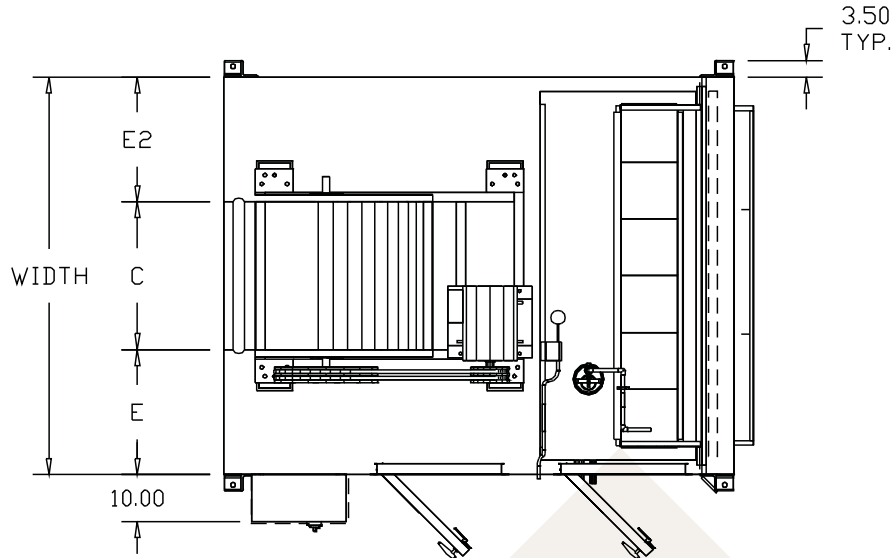

OUTSIDE CURB DIMENSIONS

Deduct 5.0" from the O.D. of the baseframe to obtain the O.D. of the roof curb. Please check submittal drawings to verify exact O.D. of the baseframe before the roof curb is built.

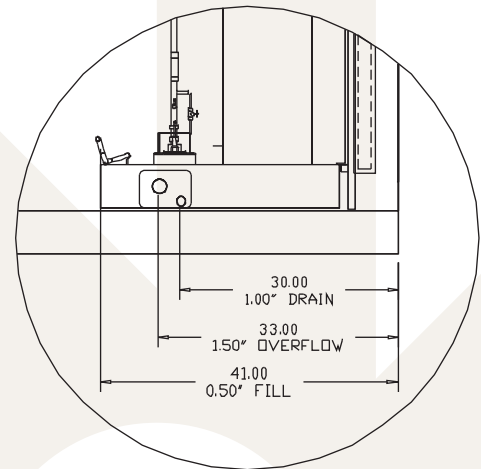

COPPER PLUMBING LOCATION DETAIL

