

**Commercial / Industrial Evaporative Cooling
16,500 to 22,500 CFM Industry Standard Rating**

Features

- External static pressure range of 0.0" to 1.2" W.G.
- Factory tested and shipped ready to operate, including factory wired components
- ETL Listed and labeled in accordance with U.L. standards
- Copper-wound, heavy duty ball bearing motors
- One high capacity pump provides complete media saturation
- Self-aligning, heavy duty, greaseable, pillow block, ball type fan bearings
- Fan performance is factory set to job specific specifications
- Aspen wood fiber media with dust trap filter
- Lifting sky hooks
- Heavy gauge, hot dipped galvanized steel construction
- Epoxy powder base paint finish baked on at 375°
- Rugged cabinet assembly with double thick steel corners
- "Rain-Tight" pitched top construction (1/4"/12")
- Adjustable motor sheave for air flow adjustment

• 400 Series

• UMP-454

- Down Discharge
- Side Discharge

Available Options

- Class II, U.L. 900 media
- Control Packages
- Clean Pump
- Installation accessories
- Fused and non-fused disconnects

Resources Available for This Product

- Catalog By Mail
- Catalog Online



United Metal Products

1920 E Encanto Drive Tempe, AZ 85281

T 480.968.9550

F 480.968.9555

www.unitedmetal.com

Model #	Industry Standard Rating	HP	AIR DELIVERY IN CUBIC FEET PER MINUTE (CFM)																									
			Inches Static Pressure (W.G.) ❶																									
			0.0		0.1		0.2		0.3		0.4		0.5		0.6		0.7		0.8		0.9		1.0		1.1		1.2	
CFM	RPM	CFM	RPM	CFM	RPM	CFM	RPM	CFM	RPM	CFM	RPM	CFM	RPM	CFM	RPM	CFM	RPM	CFM	RPM	CFM	RPM	CFM	RPM	CFM	RPM			
UMP-454 Down (D)	16,500	2	13,320	260	12,720	276	12,250	286	11,610	301	11,120	312	10,570	324	9,910	341	9,300	354										
	18,500	3	15,170	300	14,760	309	14,210	322	13,810	331	13,270	344	12,830	354	12,250	367	11,870	376	11,400	388	10,650	405						
	22,500	5	18,060	354	17,570	365	17,230	373	16,750	384	16,470	390	16,020	401	15,740	407	15,300	418	14,940	426	14,470	437	13,620	457	14,140	445	13,140	468
	24,500	7 1/2	19,400	383	19,400	399	19,400	414	19,400	428	19,180	440	18,950	445	18,540	454	18,290	460	17,920	469	17,490	479	16,790	495	17,240	485	16,520	501
UMP-454 Down (S)	16,500	2	13,320	260	12,720	276	12,250	286	11,610	301	11,120	312	10,570	324	9,910	341	9,300	354										
	18,500	3	15,170	300	14,760	309	14,210	322	13,810	331	13,270	344	12,830	354	12,250	367	11,870	376	11,400	388	10,650	405						
	22,500	5	18,060	354	17,570	365	17,230	373	16,750	384	16,470	390	16,020	401	15,740	407	15,300	418	14,940	426	14,470	437	13,620	457	14,140	445	13,140	468

Model #	ELECTRICAL SPECIFICATIONS						BLOWER UNIT		EVAPORATIVE MEDIA	WEIGHTS ❸ Down/Side	
	Fan Motor ❷			Pump			Diameter	Type	Qty.- Width x Height Down/Side	Shipping	Operate
	HP	Max BHP	Volt/Phase 115/208/230 1 Phase Amps	Volt/Phase 208/230/460 3 Phase Amps	GPH@ 5' Head	Volt/Phase 115 1 Phase Amps					
UMP-454 Down (D) Side (S)	2	2.3	24.0/ 12.6/ 12.0	5.9/ 5.6/ 2.8	380	1.2	25" X 25"	DWDI-FC	8 - 28" X 56" /6 - 28" X 56"	679 / 692	907 / 920
	3	3.45	32.0/ 16.8/ 16.0	8.7/ 8.0/ 4.0	380	1.2	25" X 25"	DWDI-FC	8 - 28" X 56" /6 - 28" X 56"	695 / 708	923 / 936
	5	5.75	--	14.0/ 13.8/ 6.9	380	1.2	25" X 25"	DWDI-FC	8 - 28" X 56" /6 - 28" X 56"	707 / 720	935 / 948
	7 1/2	8.63	--	21.0/ 19.2/ 9.6	380	1.2	25" X 25"	DWDI-FC	8 - 28" X 56" / ----	740 / ---	968 / ---

❶ 400 series, blower type evaporative coolers are designed for ducted applications with external static pressure ranges of 0.0" to 1.2". For straight down ducted low static applications with external static pressures ranges of 0.0" to 0.2" a UMP-500 series propeller type axial fan model may be recommended.

❷ Only motors 1 HP or less are provided with integral thermal protection. Motors 1.5 HP or greater require a separate motor overload device. Amperage ratings shown is nameplate data. Consult factory for overload and control options.

❸ Weights are in pounds and include motors, pumps and drives.

* Performance rating include the effects of the evaporative media, inlet louver, motor and drives in the airstream.

* Performance certified is for installation Type B: Free Inlet, Ducted Outlet

* Power rating (BHP) does not include transmission losses.





Side View

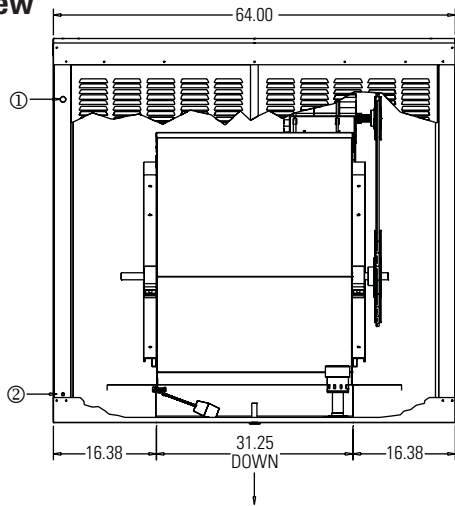

End View

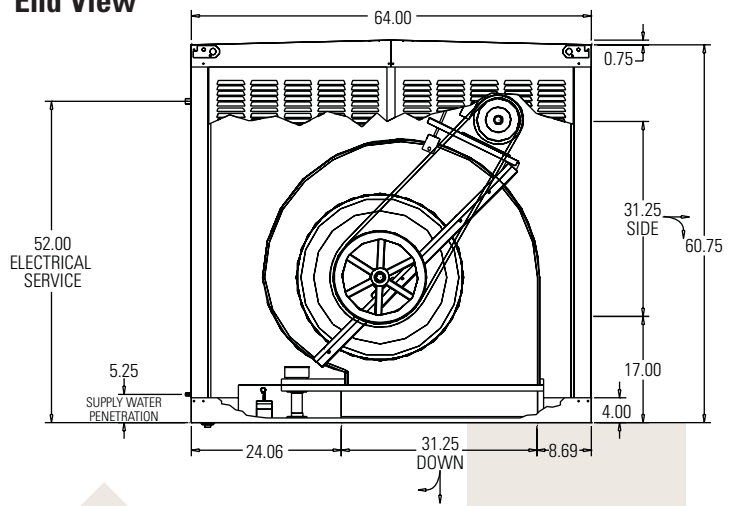

Top View

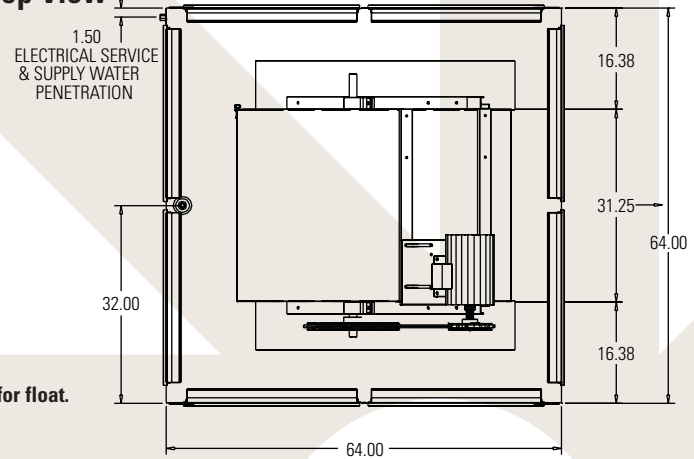

- ① 7/8" Electrical service entrance
- ② 3/8" Compression fitting connection made inside unit.

NOTE: Minimum 50 p.s.i. of water pressure required for float.