

700 Series - "Low Profile"

• **UMP-724**

-Down Discharge



**Low Profile, High Capacity, High Efficiency Evaporative Cooling
10,000 to 14,000 CFM Industry Standard Rating**

Features

- "Low profile" (only 32.00" high)
- Factory tested and shipped ready to operate, including factory wired components
- ETL Listed and labeled in accordance with U.L. standards
- Copper-wound, heavy duty ball bearing motors
- One high capacity pump provides complete media saturation
- Self-aligning, heavy duty, greaseable, pillow block, ball type fan bearings
- Fan performance is factory set to job specific specifications
- Premium 8" thick cross fluted 80% efficient media
- Lifting sky hooks
- The most up-to-date propeller type axial fan affords maximum air delivery while minimizing horsepower
- Heavy gauge, hot dipped galvanized steel construction
- Epoxy powder base paint finish baked on at 375°
- Rugged cabinet assembly with double thick steel corners
- "Rain-Tight" pitched top construction (1/4"/12")
- Easily accessible external distributor clean-outs
- Side access media removal
- Adjustable motor sheave for air flow adjustment

Available Options

- Class II, U.L. 900 media
- Prewired control packages
- Distribution flush system
- Freeze protection
- Self-tensioning belt
- Installation accessories
- Fused and non-fused disconnects

Resources Available for This Product

- Catalog By Mail
- Catalog Online



United Metal Products

1920 E Encanto Drive Tempe, AZ 85281

T 480.968.9550

F 480.968.9555

www.unitedmetal.com

Patent #4774030 or other patents pending

Model	Industry Standard Rating	AMCA LICENSED AIR DELIVERY IN CUBIC FEET PER MINUTE					ELECTRICAL SPECIFICATIONS					FAN UNIT		Evaporative Media	③ Approximate Weights (Lbs)						
		Inches Static Pressure (W.G.) ①					Fan Motor ②			Pump	Fan		Qty.-Depth x Width x Height		Shipping	Operate					
		CFM ⁰	RPM	CFM ^{0.1}	RPM	CFM ^{0.2}	RPM	CFM ^{0.3}	RPM	CFM ^{0.4}	RPM	HP		Max BHP			Volt/Phase 115/208/230 1- Phase Amps	Volt/Phase 208/230/460 3- Phase Amps	Volt/Phase 115 / 1- Phase Amps	Dia.	Max RPM
UMP-724D Down	10,000	6,827	619	5,769	596	4,626	584	2,925	584	1,554	542	1/3	0.38	5.4/2.7/2.7	----	2.3	30"	1100	10 - 8" X 12" X 24"	455	718
	12,000	7,869	713	6,946	694	6,000	676	4,946	670	3,338	670	1/2	0.58	7.2/4.1/3.6	2.1/2.3/1.5	2.3	30"	1100	10 - 8" X 12" X 24"	455	718
	13,000	8,988	813	8,188	798	7,345	781	6,499	774	5,516	767	3/4	0.86	10.6/6.0/5.3	3.0/3.4/1.7	2.3	30"	1100	10 - 8" X 12" X 24"	462	725
	14,000	9,895	896	9,095	880	8,400	867	7,669	855	6,823	848	1	1.15	13.0/6.3/6.5	3.6/3.8/1.9	2.3	30"	1100	10 - 8" X 12" X 24"	465	728

* Performance rating is at max BHP and includes the effects of the evaporative media, inlet louver, motor and drives in the airstream.
 * Performance certified is for installation Type B: Free Inlet, Ducted Outlet
 * Power rating (BHP) does not include drive losses

- ① The 700 series fan type evaporative coolers are only designed for straight down ducted applications. External static pressure ranges of 0.0" to 0.2". Higher ESP are only shown to demonstrate fan characteristics and performance with loaded media. For ducted applications with external static pressures exceeding 0.2" a UMP - 900 series blower model is recommended.
- ② Only motors 1 HP or less are provided with integral thermal protection. Motors 1.5 HP or greater require a separate motor overload device. Amperage ratings shown is nameplate data at nominal HP. Consult factory for overload and control options.
- ③ Weights are in pounds and include motors, pumps and drives. Operating weights include saturated media and assumes 2.5" depth of water in sump. Weights exclude optional accessories such as curb, diffuser and controls.
- ④ Minimum duct sizing should be 33" x 33" (see accessories drawing for details). Evaporative cooling is an adiabatic process. Possibility of water damage may exist. Special consideration must be taken when utilizing an evaporative cooler. Consult factory for special applications.



United Metal Products certifies that the Fan Air™ unit shown hereon is licensed to bear the AMCA Seal. The ratings shown are based on tests and procedures performed in accordance with AMCA Publication 211 and comply with the requirements of the AMCA Certified Ratings Program.

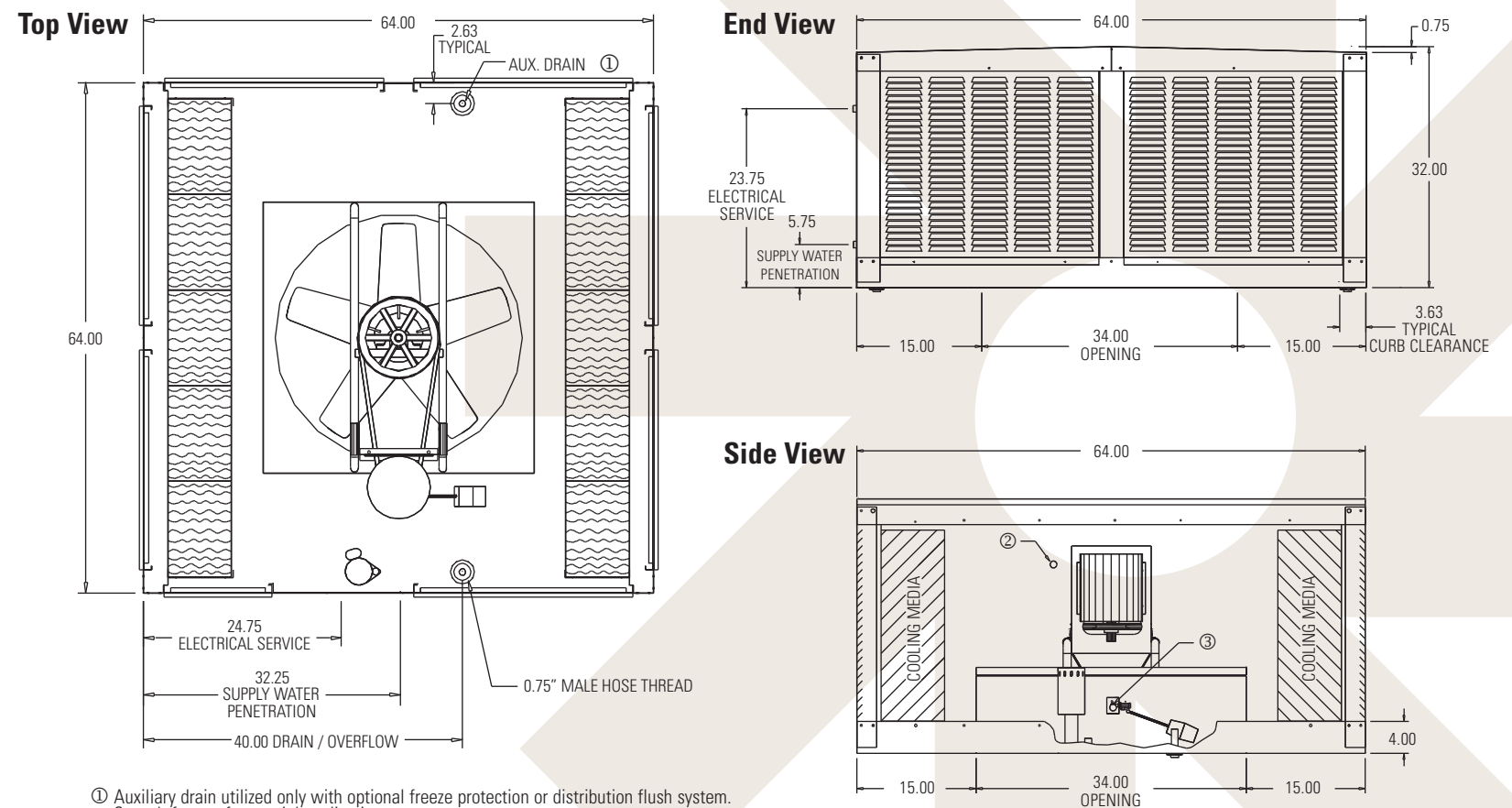

- ① Auxiliary drain utilized only with optional freeze protection or distribution flush system. Consult factory for special applications.
- ② 7/8" Electrical service entrance
- ③ 3/8" Compression fitting connection made inside unit.

NOTE: Minimum 50 p.s.i. of water pressure required for float.



UMP-724 Optional Accessories

Description	Part #	Material/Finish	Opening	Weight in Lbs.
UMP-724 Adj. Curb	7220-34	18 ga galv.	34" x 34"	45
Industrial Leg Kit	10394	16 ga painted galv.	--	7

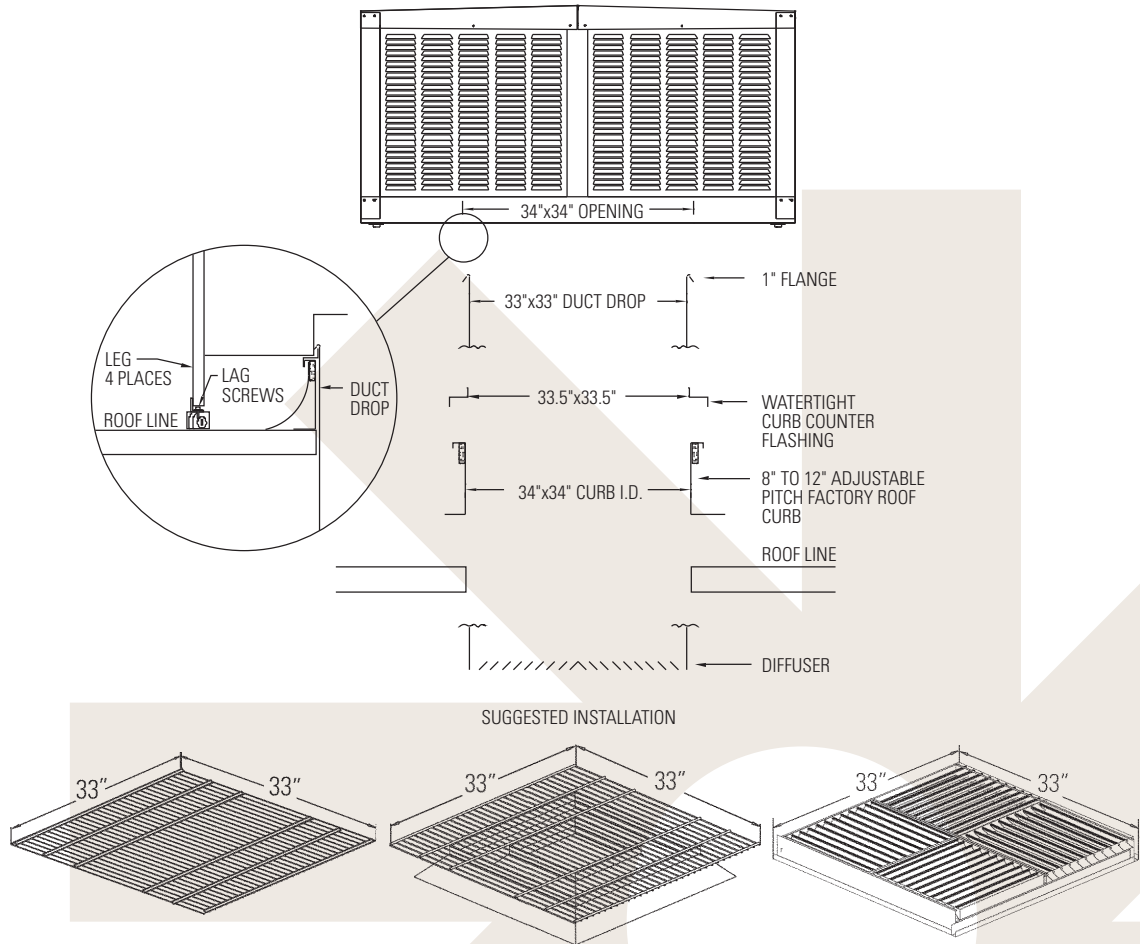

Description	UFG33 Grill	UFD33-2 Grill Diffuser	A3333 Auto Damper Diff.
Discharge Height Application	16' and above	12' to 16'	12' to 16'
Part #	80700	80701	80702
Pressure Drop @ 1,200 FPM	.02"	.07"	.10"
Material / Finish	CRS Grill / Gray	CRS Grill + Galv. Blades / Beige	CRS Grill + Aluminum / Gray
Weight in Lbs.	9	22	36

CAUTION - Guards must be installed when fan is delivering air over an occupied space, or when deemed advisable for safety. UMP diffusers feature a "safety guard" design. FAN-AIR coolers will not be provided without a diffuser or grille.