

### 700 Series - "Low Profile"

- UMP-724  
-Down Discharge



## Low Profile, High Capacity, High Efficiency Evaporative Cooling 10,000 to 14,000 CFM Industry Standard Rating

### Features

- "Low profile" (only 32.25" high)
- Factory tested and shipped ready to operate, including factory wired components
- ETL Listed and labeled in accordance with U.L. standards
- Copper-wound, heavy duty ball bearing motors
- One high capacity pump provides complete media saturation
- Self-aligning, heavy duty, greaseable, pillow block, ball type fan bearings
- Premium 8" thick cross fluted 80% efficient media
- Lifting sky hooks
- The most up-to-date propeller type axial fan affords maximum air delivery while minimizing horsepower
- Heavy gauge, hot dipped galvanized steel construction
- Epoxy powder base paint finish baked on at 375°
- Rugged cabinet assembly with double thick steel corners
- "Rain-Tight" pitched top construction (1/4"/12")
- Easily accessible external distributor clean-outs
- Side access media removal
- Adjustable motor sheave for air flow adjustment

### Available Options

- U.L. 900 media
- Prewired control packages
- Distribution flush system
- Freeze protection
- Hinged access door
- Self-tensioning belt
- Installation accessories
- Fused and non-fused disconnects

### Resources Available for This Product

- Catalog By Mail
- Catalog Online



Patent #4774030

### United Metal Products

1920 E Broadway Road Tempe, AZ 85282  
T 480.968.9550  
F 480.968.9555  
[www.unitedmetal.com](http://www.unitedmetal.com)

Model	Industry Standard Rating	AMCA LICENSED AIR DELIVERY IN CUBIC FEET PER MINUTE										ELECTRICAL SPECIFICATIONS						FAN UNIT		Evaporative Media	Weights (Lbs) ③	
		Inches Static Pressure (W.G.) ①										Fan Motor ②				Pump ④		Fan			Qty. -Depth x Width x Height	Shipping
		0		0.1		0.2		0.3		0.4		HP	Max BHP	Volt/Phase 115/208/230 1-Phase Amps	Volt/Phase 208/230/460 3-Phase Amps	GPM @ 5' Head	Volt/Phase 115 / 1-Phase Amps	Dia.	Max RPM			
UMP-724 Down	10,000	6,827	619	5,769	596	4,626	584	2,925	584	1,554	542	1/3	0.38	7.2/4.0/3.6	1.7/1.5/0.75	13.7	2.3	30"	1,100	10 - 8" x 12" x 24"	455	718
	12,000	7,869	713	6,946	694	6,000	676	4,946	670	3,338	670	1/2	0.58	9.8/5.4/4.9	2.4/2.2/1.1	13.7	2.3	30"	1,100	10 - 8" x 12" x 24"	455	718
	13,000	8,988	813	8,188	798	7,345	781	6,499	774	5,516	767	3/4	0.86	13.8/7.6/6.9	3.5/3.2/1.6	13.7	2.3	30"	1,100	10 - 8" x 12" x 24"	462	725
	14,000	9,895	896	9,095	880	8,400	867	7,669	855	6,823	848	1	1.15	16.0/8.8/8.0	4.6/4.2/2.1	13.7	2.3	30"	1,100	10 - 8" x 12" x 24"	465	728

\* Performance rating is at max BHP and includes the effects of the evaporative media, inlet louver, motor and drives in the airstream.

\* Performance certified is for installation Type B: Free Inlet, Ducted Outlet

\* Power rating (BHP) does not include transmission losses

- ① The 700 series fan type evaporative coolers are only designed for straight down ducted applications. External static pressure ranges of 0.0" to 0.2". Higher ESP are only shown to demonstrate fan characteristics and performance. For ducted applications with external static pressures exceeding 0.2" a UMP - 900 series blower model is recommended. Evaporative cooling is an adiabatic process. Possibility of water damage may exist. Special consideration must be taken when utilizing and evaporative cooler. Consult factory for special application.
- ② Only motors 1 HP or less are provided with integral thermal protection. Motors 1.5 HP or greater require a separate motor overload device. Amperage ratings shown are NEC at nominal HP. Consult factory for overload and control options.
- ③ Weights are in pounds and include motors, pumps and drives. Operating weights include saturated media and assumes 2.5" depth of water in sump. Weights exclude optional accessories such as curb, diffuser and controls.
- ④ 230v pumps are available; contact UMP for details.



United Metal Products certifies that the Fan Air™ unit shown hereon is licensed to bear the AMCA Seal. The ratings shown are based on tests and procedures performed in accordance with AMCA Publication 211 and comply with the requirements of the AMCA Certified Ratings Program.



## UMP-724

Top View

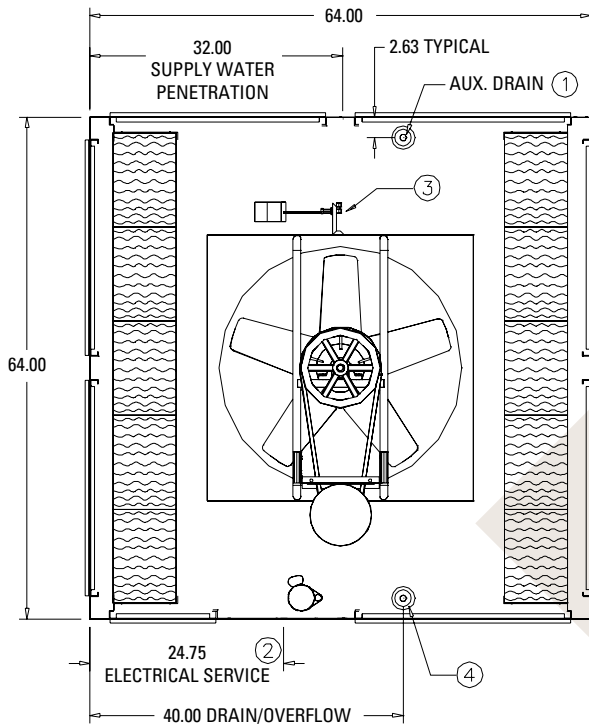

End View

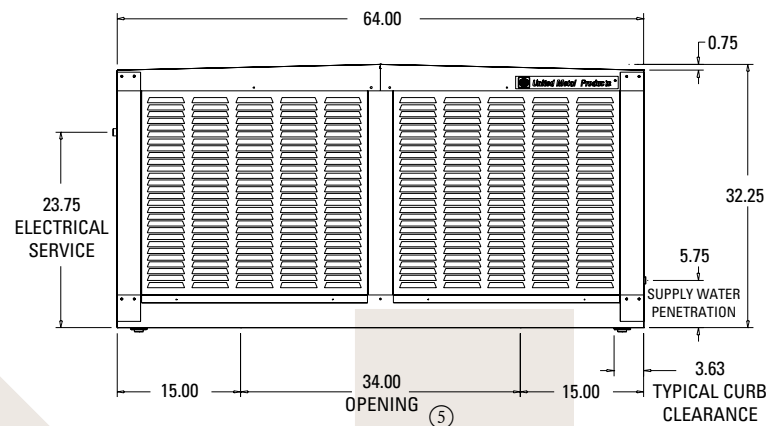

Side View

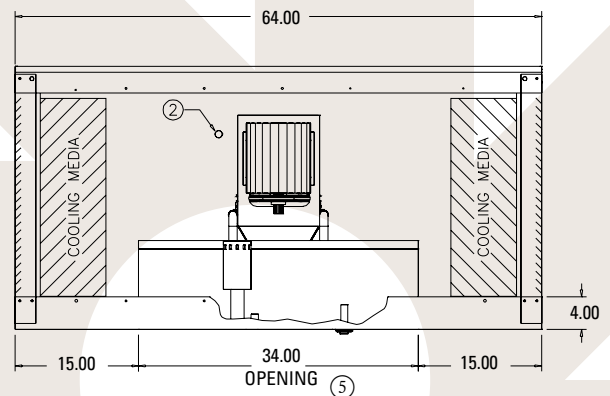

- ① **Auxiliary Drain** - (3/4" male hose thread) - Consult factory for special applications.
  - A. **Distributor Flush System** - May be externally plumbed (by others). The installer has the option to run the flush line internally to the overflow tube or secure the flushline back into the sump. If the installer chooses to run the flush line internally to the auxiliary drain then it will be necessary to externally plumb the auxiliary drain.
  - B. **Freeze Kit** - Must be externally plumbed (by others) when utilizing optional Freeze Kit. Note: When the optional Freeze Kit is used in conjunction with the optional Flush Kit, the flush line will be factory mounted into the sump only.
- ② **Electrical Service** - 7/8" entrance for 1/2" conduit.
- ③ **Float** - 3/8" Compression fitting connection made inside unit. Minimum 15 p.s.i. water pressure is recommended to deliver the volume needed to meet high summer evaporation and bleed requirements. Do not exceed 125 p.s.i.
- ④ **Primary Drain / Overflow** - (3/4" male hose thread) must be externally plumbed (by others).
- ⑤ **Duct Size** - Recommended duct size 33" x 33".