

## Low Profile, Commercial / Industrial Evaporative Cooling 27,500 to 29,500 CFM Industry Standard Rating

### Features

- "Low profile" (only 59.25" high)
- External static pressure range of 0.0" to 1.2" W.G.
- Factory tested and shipped ready to operate, including factory wired components
- ETL listed and labeled in accordance with U.L. standards
- Copper-wound, heavy duty ball bearing motors
- One high capacity pump provides complete media saturation with 8" deep media. Two pumps are used with 12" deep media.
- Self-aligning, heavy duty, greaseable, pillow block, ball type fan bearings
- Premium 8" or 12" thick cross fluted media for 80% to 90% evaporative efficiency
- Lifting sky hooks
- Heavy gauge, hot dipped galvanized steel construction
- Epoxy powder base paint finish baked on at 375°
- Rugged cabinet assembly with double thick steel corners
- "Rain-Tight" pitched top construction (1/4"/12")
- Easily accessible external distributor clean-outs
- Side access media removal
- Adjustable motor sheave for air flow adjustment
- Epoxy painted G-90 galvanized steel reservoir

### • 900 Series - "Low Profile"

- UMP-951
  - Up Discharge
  - Side Discharge
  - Down Discharge

### Available Options

- U.L. 900 media
- Prewired control packages
- Distribution flush system
- Freeze protection
- Hinged access door
- 2" Pre-filters
- Installation accessories
- Fused and non-fused disconnects

### Resources Available for This Product

- Catalog By Mail
- Catalog Online



Patent #4774030 or other patents pending

### United Metal Products

1920 E Broadway Road Tempe, AZ 85282  
T 480.968.9550  
F 480.968.9555  
[www.unitedmetal.com](http://www.unitedmetal.com)

Model	Industry Standard Rating	Media Depth	Eff'y @ 500 FPM	HP	AIR DELIVERY IN CUBIC FEET PER MINUTE																									
					Inches Static Pressure (W.G.) ❶																									
					0		0.1		0.2		0.3		0.4		0.5		0.6		0.7		0.8		0.9		1.0		1.1		1.2	
CFM	RPM	CFM	RPM	CFM	RPM	CFM	RPM	CFM	RPM	CFM	RPM	CFM	RPM	CFM	RPM	CFM	RPM	CFM	RPM	CFM	RPM	CFM	RPM	CFM	RPM					
UMP-951 Up (U)	27,500	8"	80%	7 1/2	21,540	387	21,100	396	20,650	406	20,400	412	19,980	421	19,580	431	19,250	438	18,850	447	18,470	456	18,170	463	17,780	472	17,390	481	17,050	489
		12"	90%	7 1/2	21,250	393	20,780	403	20,360	413	20,100	418	19,680	428	19,250	438	19,030	443	18,610	453	18,200	462	17,950	468	17,530	478	17,140	487	16,830	494
UMP-951 Side (S) Down (D)	29,500	8"	80%	10	23,800	426	23,380	434	22,980	443	22,680	449	22,300	458	21,920	467	21,680	472	21,290	481	20,920	489	20,680	494	20,335	503	19,990	511	19,610	520
		12"	90%	10	23,410	433	23,000	442	22,610	451	22,350	456	21,980	465	21,600	474	21,410	478	21,000	487	20,680	495	20,410	500	20,080	509	19,730	517	19,350	526

Model	ELECTRICAL SPECIFICATIONS						BLOWER UNIT		Evaporative Media	Weights (Lbs) ❸	
	Fan Motor ❷				Pump ❹		Dia.	Type	Qty.-Depth x Width x Height	Shipping	Operate
	HP	Max BHP	Volt/Phase 115/208/230 1-Phase Amps	Volt/Phase 208/230/460 3-Phase Amps	GPH @ 5' Head	Volt/Phase 115/ 1-Phase Amps					
UMP-951 Up (U) Side (S) Down (D)	7 1/2	8.63	--	24.2/22.0/11.0	820	2.3	25" x 25"	DWDI-FC	10 - 8" x 12" x 51"	1,098	1,528
	7 1/2	8.63	--	24.2/22.0/11.0	1,640	4.6	25" x 25"	DWDI-FC	10 - 12" x 12" x 51"	1,154	1,635
	10	11.5	--	-- / -- /14.0	820	2.3	25" x 25"	DWDI-FC	10 - 8" x 12" x 51"	1,101	1,531
	10	11.5	--	-- / -- /14.0	1,640	4.6	25" x 25"	DWDI-FC	10 - 12" x 12" x 51"	1,157	1,638

- ❶ UMP-900 series, blower type evaporative coolers are designed for ducted applications with external static pressure ranges of 0.0" through 1.2". For straight down ducted low static applications with external static pressure ranges of 0.0" to 0.2" a UMP-700 series propeller type axial fan model may be recommended.
- ❷ Only motors 1 HP or less are provided with integral thermal protection. Motors 1.5 HP or greater require a separate motor overload device. Amperage ratings shown are NEC at nominal HP. Usable at 208v. Consult factory for overload and control options.
- ❸ Weights are in pounds and include motors, pumps and drives. Operating weights include saturated media and assumes 2.5" depth of water in sump. Weights exclude optional accessories such as curb, diffuser and controls.
- ❹ 230v pumps are available; contact UMP for details.

\* Performance rating is at max BHP and includes the effects of the evaporative media, inlet louver, motor and drives in the airstream.  
 \* Fan performance shown is based on tests made in accordance with AMCA 210-85, installation Type B; free inlet, ducted outlet.  
 \* Power rating (BHP) does not include drive losses

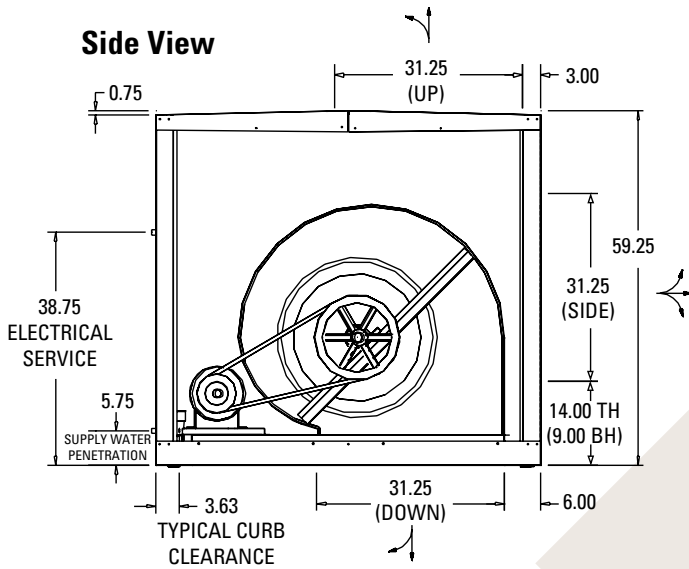
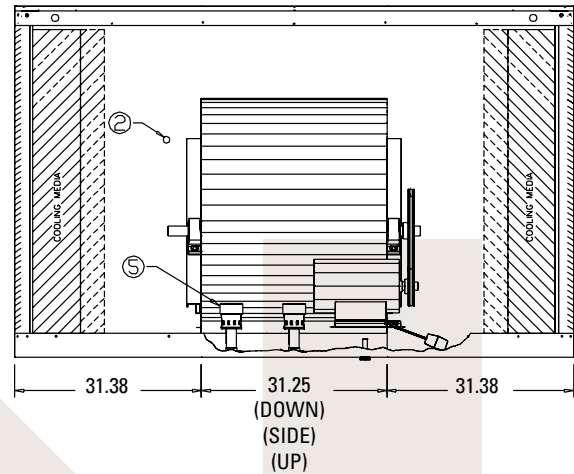
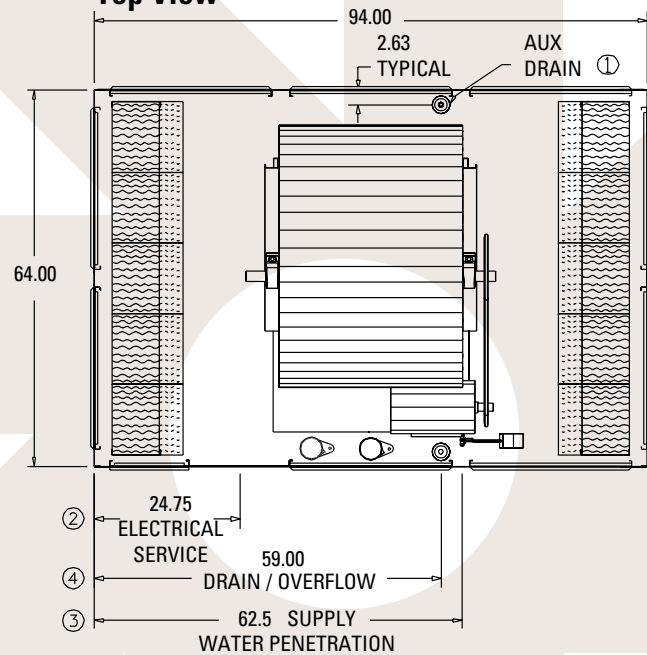

**UMP-951**
**Side View**

**End View**

**Top View**

- ① Auxiliary drain utilized only with optional freeze protection or distribution flush system. Consult factory for special applications.
- ② 7/8" Electrical service entrance for 1/2" conduit.
- ③ 3/8" Compression fitting connection made inside unit. Minimum 50 p.s.i. water pressure is recommended to deliver the volume needed to meet high summer evaporation and bleed requirements. Do not exceed 125 p.s.i.
- ④ 3/4" Male hose thread.
- ⑤ (1) pump is used with 8" deep media. (2) pumps are used with 12" deep media.