



## NOTE! READ AND SAVE THIS MANUAL — IMPORTANT SAFETY INSTRUCTIONS

### USE AND CARE INFORMATION FOR UNITED METAL PRODUCTS Fan-Air® EVAPORATIVE COOLERS

The selection of evaporative cooling as a method of cooling your building will provide maximum cooling at minimum operating expense. Your evaporative cooler unit is designed and built to provide many years of dependable operation. The following information includes sections on installation, start-up and regular maintenance. NOTE: If any assistance from the factory is needed to check, test, or start-up any UMP equipment, a prevalent rate per day, per person plus travel, lodging, food, etc., will be paid by the buyer/contractor.

### INSTALLATION AND START-UP SAFETY

- An evaporative cooler should only be installed by a qualified and experienced installer in which all work should be in compliance to all local and national electrical codes.
- Before installation it is important to be certain the mounting surface will bear the operating weight of the unit. For proper unit operation it is also important that it be operated in a completely level position.
- Electrical wiring must be installed a safe distance away from any sharp or moving parts (blower wheels, pulleys, sheaves, belts, etc.) and in accordance with the NEC and local codes.
- Either an open drip proof or totally enclosed fan cooled motor may be used. Check the electrical supply to see that it matches the requirements shown on the motor name plate.
- Guards must be installed when the rotating fan prop or wheel is operating above an occupied space or within 7ft of working area or whenever deemed advisable for safety reasons.
- Evaporative media should be wetted-out, dried and reservoir drained, and then repeat process one more time before running for normal operation.
- A bleed-off or flush system is required to reduce scale from formation on the evaporative media; prolonging media life.
- Before start-up and after servicing and cleaning, all safety devices and panels must be installed and operating.

### PRE-START CHECK LIST

Complete and fax a copy of the enclosed Pre-Start Checklist to United Metal Products within 30 days of start-up to validate the evaporative cooler warranty

**WARNING - TO REDUCE THE RISK OF FIRE, ELECTRIC SHOCK, OR INJURY TO PERSONS, OBSERVE THE FOLLOWING:**

Installation work and electrical wiring must be done by qualified person(s) in accordance with all applicable codes and standards, including fire-rated construction.

When cutting or drilling into wall or ceiling, do not damage electrical wiring and other hidden utilities.

For future reference, record Model and Serial Numbers of your evaporative cooler here:  
(Numbers are located on the outside of the unit.)

Model No. \_\_\_\_\_ Serial No. \_\_\_\_\_

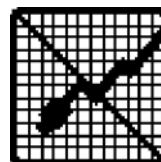

#### **SAFETY**

**Caution: DISCONNECT ALL ELECTRICAL POWER TO THE UNIT BEFORE ATTEMPTING TO INSTALL, OPEN, OR SERVICE YOUR UNIT. IF THE UNIT IS THERMOSTATICALLY CONTROLLED, THE THERMOSTAT IS NOT TO BE USED AS A DISCONNECT AS IT MAY RESET AND START THE UNIT UNEXPECTEDLY.**



# START-UP PROCEDURE

## RECEIVING

Inspect the complete unit for shipping damage. If damage is present, you have the right to either accept or reject the shipment. If the receiving contractor or the receiving agent or the contractor elects to receive the equipment in a damaged condition, it then becomes the contractor's responsibility to note the extent of the damage on the delivering freight bill of lading in the presence of the delivering agent (driver) of the delivering freight carrier in accordance with the ICC regulations. It also then becomes the responsibility of the receiving contractor to work with the delivering carrier to have the equipment repaired to the satisfaction of United Metal Products, Inc., so the warranty may remain valid. United Metal Products will also be notified of shipping damage immediately. Be sure to read the warranty for further information. United Metal Products will in no way be responsible for any unauthorized back charges due to events or circumstances out of their control which may cause shipping delays.

## INSPECTION OF EQUIPMENT-VISUAL

The equipment type and arrangement should be verified as ordered at once when it arrives at the jobsite. When a discrepancy is found, the local United Metal Products Sales Representative must be notified immediately so that corrective action may be investigated, also verify electrical conformance to specifications. Unauthorized alterations and unauthorized back charges will not be recognized by United Metal Products, Inc.

## LONG-TERM STORAGE

There is a time limit of one year from date of shipment that any unit may be kept in long-term storage. At the end of the one year period, the unit must be in operation. Rotate the wheel by hand every two weeks to redistribute grease on internal bearing parts.

NOTE: Failure to perform the long-term storage requirements past 60 days from shipment and properly log these required procedures will void the warranty.

## INSTALLATION AND START-UP SAFETY

- Before installation it is important to be certain the mounting surface will bear the operating weight of the unit. For proper unit operation, it is also important that it be operated in a completely level position.
- Electrical wiring must be installed a safe distance away from any sharp or moving parts (blower wheels, pulleys, sheaves, belts, etc.).
- All guards and/or interlocks, mechanical or electrical, provided by manufacturer must always remain in place to provide needed protection against moving parts.

## CURB INSTALLATION (Optional)

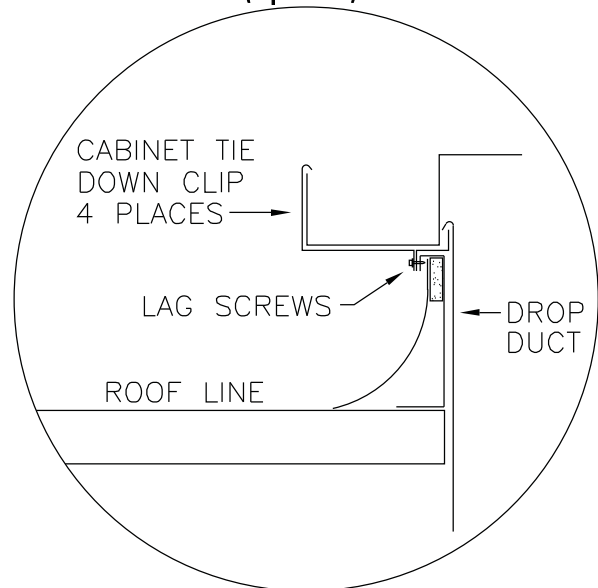

FIGURE A.

When installing the curb, obtain a copy of the approved submittal, as each unit and actual curb installation may not be identical. Do not use this typical curb installation detail (Figure A) to install your curb.

NOTE: The curb may be shipped unassembled. It may be necessary to assemble it on the jobsite. Each part of the curb is identified with the proper tags and/or markings. It is important the curb be installed level and square.

NOTE: See section under receiving instructions when receiving curbs and inspecting for freight damage and filing of freight damage claims. Any freight damage is the responsibility of the receiving contractor and/or his authorized receiving agent and the delivering carrier.

NOTE: Should there be any questions as to the number of pieces or curb parts or assembling of the curb, contact United Metal Products at once.

- Guards must be installed when the rotating fan prop or wheel is operating above an occupied space or within 7ft of working area or whenever deemed advisable for safety reasons.
- All safety devices, panels, and doors of the unit must be installed and remounted as previously mounted before start-up, servicing, or cleaning.
- Do not start-up blower units with no ductwork attached or motor may over-amp and cause damage.
- Check for leaks.
- Check belt tension.

# PRE-START CHECKLIST

(RESPONSIBILITY OF INSTALLING CONTRACTOR)

NOTE: Please complete & return fax to  
United Metal Products within 30 days of  
start-up for warranty validation.  
Fax: 480-968-9555

INSTALLER \_\_\_\_\_ COMPANY \_\_\_\_\_ DATE \_\_\_\_\_  
MODEL NUMBER \_\_\_\_\_ SERIAL NUMBER \_\_\_\_\_ TAG NUMBER \_\_\_\_\_

## Y N NA FAN / BLOWER

1.    bearing blocks tight and aligned
2.    bearing concentrics tight
3.    driven pulley and hub tight
4.    remove shipping blocks
5.    set screws in blower hub tight and secure  
(NOTE: after two weeks of operation - retighten)

## MOTOR(S)

6.    mounting bolts tight
7.    electrical connections and cover tight
8.    pulley and hub tight

## BELTS

9.    guard in place and secure
10.    belts are aligned and correctly tensioned

## WET SECTION

11.    media clean & in place. Fluted media has the 45° flutes sloping down towards the air entering side
12.    Connect site water line to cooler float valve. Size = To match float valve. Line pressure = Min. 50 psi / Max. 125 psi.
13.    fill water reservoir to a level of 2 1/2" to 3" or as necessary and set the float to maintain that maximum level not to exceed standpipe
14.    flush/bleed tubing secure in overflow
15.    adjust pump flow rate to deliver the required flow evenly over the media
16.    fill and drain actuators operate properly
17.    flush and drain the media and sump a minimum of twice before operating the cooler (this prevents water carry-over)

## Y N NA ELECTRICAL CONNECTIONS

18.    all electrical connections tight
19.    prove out door safety switches (where fitted)

## CABINET

20.    remove isolator tie downs if provided
21.    tighten any bolts or screws that may be loose
22.    the cooler is level
23.    check for leaks
24.    all safety devices, panels and doors of unit must be installed before start-up, and reinstalled after servicing or cleaning.

## OPERATION

25.    amps
26.    fan / blower noise
27.    rotation correct
28.    air capacity & external static pressure
29.    vibration
30.    all safety devices installed and secure
31.    thermal overloads set properly

## WARNING:

If the cooler is not installed on a flat and level surface the fan may become out of alignment. Before applying power to the motor for the first time, rotate the fan/blower by hand and check that the blade tip clearance is the same at all points around the fan discharge. Make any adjustments necessary to ensure that the fan is centered and free to rotate.

## COMMISSIONING RECORD

### SUPPLY FAN

	AMPS			VOLTS		
A.	L1 _____	L2 _____	L3 _____	L1 - L2 _____	L1 - L3 _____	L3 - L2 _____
B.	L1 _____	L2 _____	L3 _____	L1 - L2 _____	L1 - L3 _____	L3 - L2 _____
Final Overload Setting _____						
Nameplate: Model # _____ Volts _____ Amps _____ HP _____						

### PUMPS

A.	L1 _____	L2 _____	L3 _____	L1 - L2 _____	L1 - L3 _____	L3 - L2 _____
B.	L1 _____	L2 _____	L3 _____	L1 - L2 _____	L1 - L3 _____	L3 - L2 _____
Nameplate: Model # _____ Volts _____ Amps _____ HP _____						

Verify all Amp and Volt readings meet nameplate data

Installer's Acceptance Signature X \_\_\_\_\_ Date \_\_\_\_\_

NOTES: \_\_\_\_\_

# REGULAR MAINTENANCE AND ANNUAL START-UP

The commercial / industrial evaporative cooling unit you selected may be either horizontal discharge, down discharge or up discharge. The down discharge unit is designed for either flat or pitched roofs. The side discharge unit is designed for either the side of a building or on a flat or pitched roof. The up discharge unit is primarily designed for ground mount application. In all applications, care must be taken that the fan or blower is facing an unoccupied space only. Guards must be installed when the rotating fan prop or wheel is operating above an occupied space or within 7ft of working area or whenever deemed advisable for safety reasons.

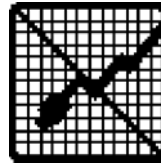

## SAFETY

**Caution: DISCONNECT ALL ELECTRICAL POWER TO THE UNIT BEFORE ATTEMPTING TO INSTALL, OPEN, OR SERVICE YOUR UNIT. IF THE UNIT IS THERMOSTATICALLY CONTROLLED, THE THERMOSTAT IS NOT TO BE USED AS A DISCONNECT AS IT MAY RESET AND START THE UNIT UNEXPECTEDLY.**

For efficient operation it is crucial that your evaporative cooler be properly maintained each year. The cooling capability of any cooler will be severely limited if regular maintenance is neglected for even one year. Therefore, the following maintenance information must be applied at the recommended intervals in order to receive maximum benefit from the cooler.

## MAINTENANCE TIMETABLE

Function	Annual Start-up	During Season	Annual Shut-down
WASH EVAPORATIVE MEDIA		X	X
CLEAN WATER PUMP	X	X	
CLEAN PUMP SCREEN	X	X	
CHECK BELT TENSION	X	X	
LUBRICATION	X	X	
CLEAN RESERVOIR	X	X	
ADJUST WATER FLOW	X	X	
DRAIN RESERVOIR			X
ADJUST BLEED-OFF	X	X	

### 1.0 FLUTED EVAPORATIVE COOLER MEDIA.

This section is for evaporative coolers fitted with either 8" or 12" deep cross fluted media. Pads should be checked for salt build-up at beginning and end of season. Scale build-up can occur when heavy salt-laden water is not diluted correctly. If pads scale and are plugged, they should be hosed down to clean away dirt and salt particles.

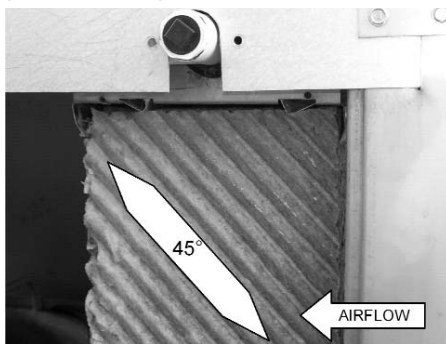

FIGURE 1.1.

If the pads become too blocked the cooling efficiency and air delivery will be reduced and the pads should be replaced. The media can be replaced by removing the outer access panels and the internal media cover plate, and then sliding the media along the bottom drain rack. The inlet louver panels may also

be removed to help with this task if necessary. The media can be withdrawn from either side of the cooler. When replacing media, be sure that the 45 degree angled flutes are slanted downward toward the entering air stream (Figure 1.1)

### RECOMMENDED FLUTED MEDIA REPLACEMENT SIZES

MODEL	SIZE (WxDxH)	QUANTITY
UMP-639S	12 x 8 x 39	5
UMP-644S	12 x 8 x 44	5
UMP-639x2S	12 x 8 x 39	9
UMP-644x2S	12 x 8 x 44	9
UMP-724	12 x 8 x 24	10
UMP-730	12 x 8 x 30	10
UMP-739	12 x 8 x 39	10
UMP-739 XL	12 x 8 x 39	15
UMP-751	12 x 8 x 51	10
UMP-751 XL	12 x 8 x 51	15
UMP-824 U, S or D	12 x 8 x 24 or 12 x 12 x 24	5
UMP-839 U, S or D	12 x 8 x 39 or 12 x 12 x 39	5
UMP-939 U, S or D	12 x 8 x 39 or 12 x 12 x 39	10
UMP-951 U, S or D	12 x 8 x 51 or 12 x 12 x 51	10

NOTE: If unit is supplied with U.L. Class 2 media, remove and replace with same.

## 2.0. INSTALLING OVERFLOW STANDPIPE

Slide rubber washer over drain bushing, push drain bushing through bottom of cooler, and tighten nut. Screw plastic overflow standpipe into drain bushing and tighten snugly to prevent leakage. On cooler with an auxiliary drain, plug this bushing unless you are utilizing the optional freeze protection or distributor flush system. Connect drain line to drain bushing (standard 3/4" -11.5 Hose coupling threads) or 3/4" NPT female connector (where provided) and drain in accordance to local codes.

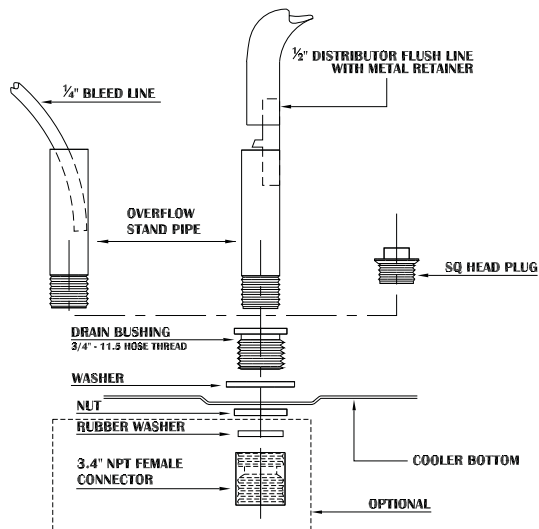

## 3.0. WATER BLEED-OFF SYSTEM

A water bleed-off or flush system is essential in order to fight scale build-up, prevent excessive salts and corrosion build-up, and prolong the life of the unit. Throughout the life of the evaporative cooler pads, adjust the amount of bleed-off during regular maintenance to maintain the pH of the water between 6 and 8.

For coolers equipped with a manual bleed system, adjust the flow rate while the pump is working and discharge the bleed water directly into the overflow standpipe.

For coolers equipped with an automatic distributor flush system, the timer can be adjusted to increase/decrease the length of time the flush valve is open as well as the period of time between flush cycles. The timer is wired in series with the pump and is only energized when the pump is operating. This allows the cooler to perform the flush cycle based on the number of actual operating hours. The flush valve should be dismantled and cleaned out each season to ensure it does not become blocked.

## 4.0. WATER DISTRIBUTOR CLEAN-OUT

If distribution pipe or orifice becomes clogged, it should be cleaned out. Evaporative coolers with fluted pad media have a removable plug at the end of each water distributor to allow for proper cleaning of the water distribution pipe (Figure 4.0). Cleaning can generally be achieved by removing the distributor end cap and running the pump. If the contamination is not cleared with this method, high pressure water and/or a dis-



FIGURE 4.0.



FIGURE 4.1.

tributor cleaning rod may be used. For a visual inspection and manual cleanout of the water distributor, the whole distributor pipe can be withdrawn from one side of the cooler (Hybrallume units only) (Figure 4.1).

Remove the access panel and roof edge cover below the distributor. Remove the inside hose from the end of the distributor pipe and the pipe support that attaches to the cooler roof. To make re-assembly easier, we recommend that both distributor end caps are removed at this point and a 1/2" diameter x 6ft long rod or dowel is pushed into the distributor. Secure the end of the dowel at the end opposite to where the distributor will be removed so that it stays within the cooler when the distributor pipe is removed. Take hold of the distributor pipe where the hose was attached and rotate it down so that it is vertical (this will break the seal at the opposite end of the distributor pipe) and then pull the complete pipe horizontally out of the cooler (without removing the dowel) (Figure 4.2). Clean out the distributor.

Apply a small amount of watertight lubricant (such as AquaShield or AquaLube waterproof lithium based grease) to the first inch of the outside of the distributor pipe and insert it over the dowel and into the cooler (Figure 4.3). The dowel will help to re-locate the "T" fitting at the other end of the distribu-

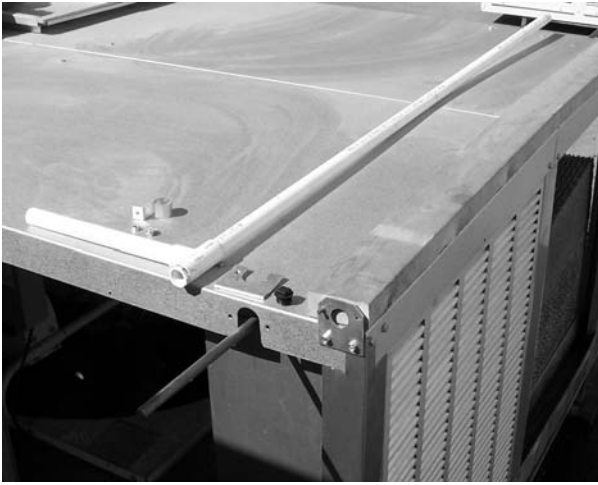

FIGURE 4.2.

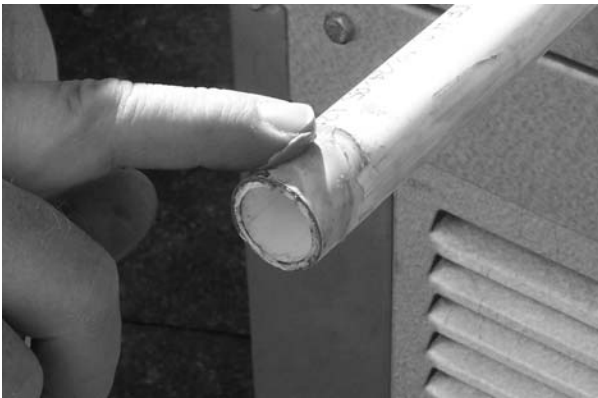

FIGURE 4.3.

tor assembly. When the distributor pipe is correctly mated with the "T" fitting the distributor pipe can be rotated back to its original position. Re-attach the distributor pipe support and the flexible hose. Remove the dowel and re-insert the distributor end caps. Note: Distributor pipes in multi-inlet coolers are made right hand and left hand. When re-inserting the distributor pipes make sure the distributor holes will be facing UP when it is rotated to its final position.

## 5.0. CLEANING THE WATER PUMP AND RESERVOIR

### ALWAYS DISCONNECT POWER BEFORE SERVICING PUMP.

Snap the plastic grid off the bottom of the pump and clean. A removable media frame has been provided in fluted pad type coolers (Figure 5.0). Remove old debris from the reservoir. We recommend coating painted galvanized steel reservoirs with high quality sub-sealer after the first year of operation and as needed.

## 6.0. SETTING THE WATER FLOW RATE

Adjust the water flow over the evaporative media pads by the in-line valve (where provided) on each unit. The recommended maximum flow rate is 1.5 GPM per sq. ft. over the top of the pad. (Figure 6.0)

## 7.0. ASPEN EVAPORATIVE PAD MEDIA

This section is for evaporative coolers fitted with Aspen type



FIGURE 5.0.

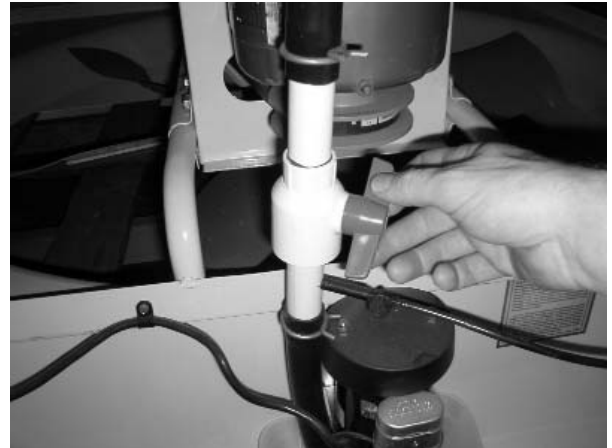

FIGURE 6.0.

cooling media. It is advisable to change the aspen pads twice during the cooling season-in the beginning of the season and half way through it. Only a high quality pad should be installed. A poorly packed pad with air gaps in it will deliver warm air and draw water droplets into the system. On all fan coolers a spun glass air filter must be installed on the inside between the Aspen and wire retainer rack (see Figure 7.2.C).

Replace pads and filter screen as follows:

- A. Remove pad frame from cabinet by lifting from the bottom edge and pulling outward and then letting it drop (Figure 7.2.A).
- B. Remove wire retainer and discard old pad(s) and filter.
- C. Wash dirt and scale from pad frame with a mild detergent if necessary.
- D. Lay the new pad in the frame starting at the trough or top end. Tuck pad under trough (toward outside surface of the pad (Figure 7.2.B). Tuck edges inside the frame all the way around, making sure there are no air gaps. It is important to do this step correctly to avoid water spray problems.
- E. Lay the spun filter on top of the pads. Reinstall the wire rack-apply pressure to push sharp points into the pad (Figure 7.2.C).



FIGURE 7.2.A.



FIGURE 7.2.B.



FIGURE 7.2.C

## RECOMMENDED ASPEN PAD REPLACEMENT SIZES

MODEL	SIZE (W x H)	QUANTITY
UD2140L, UMP-536	30 x 36	8
UD3640L	30 x 36	10
US2140, UMP-454S, UMP-554S	28 x 56	6
S3680	28 x 56	7
UD2140, UMP-454D, UMP-554D	28 x 56	8
UD3640, D3680	28 x 56	10

NOTE: If unit is supplied with U.L. Class 2 media, remove and replace with same.

## 8.0. BELT TENSION AND ALIGNMENT

With each cooler inspection be sure to check for proper belt tension and alignment.

**Important:** When assembling the motor and drive, the sheaves must be aligned to keep the belt straight. This is accomplished by ensuring that the motor and fan sheave grooves are directly in line with one another.

Proper belt tension is approximately ½" movement of the belt when pressed at mid-span under normal thumb pressure. Do not over tighten belt. However, a new belt should be tighter than a used belt. (FIGURE 8.1)

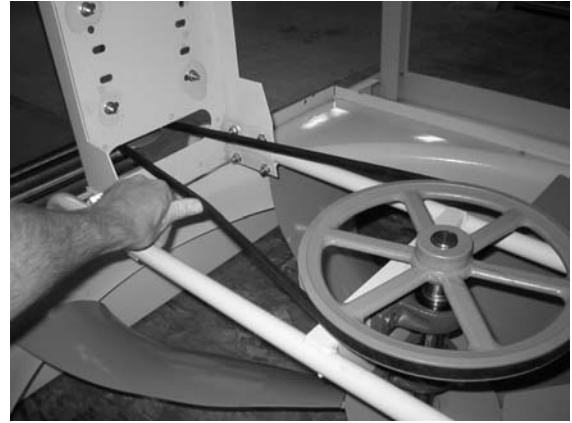

FIGURE 8.1 - Belt Tension - Propeller Fan Coolers Shown

## 9.0. BEARING LUBRICATION

Ball bearings pillow blocks (Fan) - Suggested initial greasing interval (6 Months). Adjust lubrication frequency depending hours of operation, temperature, and surrounding condition that will affect the relubrication frequency required. Lubricate the bearings prior to extended shutdown or storage and rotate shaft monthly to aid corrosion protection. Caution: Do not over grease. The major cause of premature bearing failure is over greasing. Type of Grease: Lubricate with a high quality NLGI No. 2 or 3 multipurpose ball bearing grease having rust inhibitors and antioxidant additives. Recommended grease: Shell - Alvania No. 2, Gulf - Gulfcrown No. 2, Mobil - Mobilith AW2/Mobilith SHC100 and American - Rykon Premium 2.

Motor bearing grease will lose its lubricating ability over time, not suddenly. Good results can be obtained if the following recommendations are used in your maintenance program. Type of Grease: A high grade ball bearing grease should be used. Recommended grease for standard service conditions is Polyrex EM (Exxon Mobil). Equivalent and compatible greases include: Texaco Polystar, Rykon Premium # 2 and Chevron SRI. Lubrication Intervals: these recommended intervals are based on average use. NEMA Frame size up to 210 - 6000 hours, NEMA Frame 210 to 280 - 4750 hours.

## 10.0. FAN AND BLOWER ASSEMBLIES

Whether the evaporative cooler is fitted with a propeller fan or a blower fan, correct set-up and maintenance is required.

**SAFETY NOTE: GUARDS MUST BE INSTALLED WHEN THE ROTATING FAN PROP OR WHEEL IS OPERATING ABOVE AN OCCUPIED SPACE OR WITHIN 7FT OF WORKING AREA OR WHENEVER DEEMED ADVISABLE FOR SAFETY REASONS.**

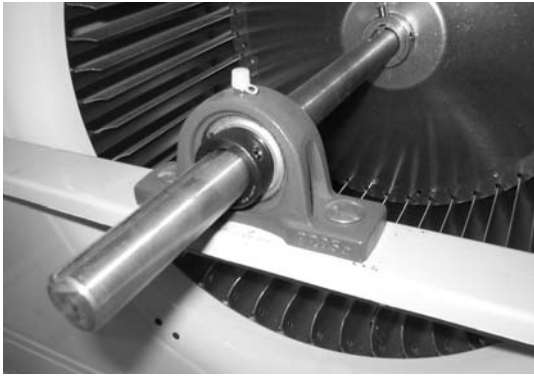
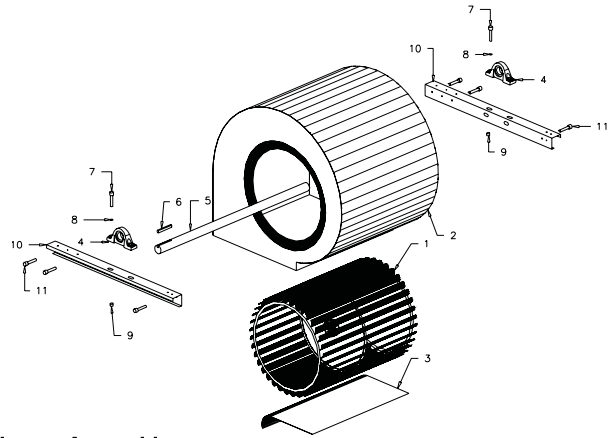

FIGURE 9.0 - Typical for fan and blower coolers



**Blower Assembly**

Ref. No.	Description	Qty
1	Blower wheel	1
2	Blower housing	1
3	Blower cut-off plate	1
4	Bearing	2
5	Shaft	1
6	Shaft key	1
7	Bolt	4
8	Washer	4
9	Locknut	4
10	Bearing rail	2
11	Bolt	8

**ANNUAL SHUT-DOWN**

At the end of the cooling season it will be necessary to turn off the water supply to the cooler. Unscrew and remove the standpipe to allow the water to drain down (Figure 11.0). Do not leave water standing in unit for prolonged periods of time while unit is not in use. Apply a coat of high quality sub-sealer to painted galvanized steel reservoirs after the first year of operation and as needed.

Gently hose stubborn deposits from the face of the evaporative media with fresh water. Run fresh water through the pump and water distribution system for 30 minutes (with the fan / blower turned off if possible) to flush out mineral deposits and leave the evaporative media as clean as possible.

**NOTE: NEVER OPERATE THE WATER PUMP WITHOUT HAVING THE RESERVOIR FILLED WITH WATER**

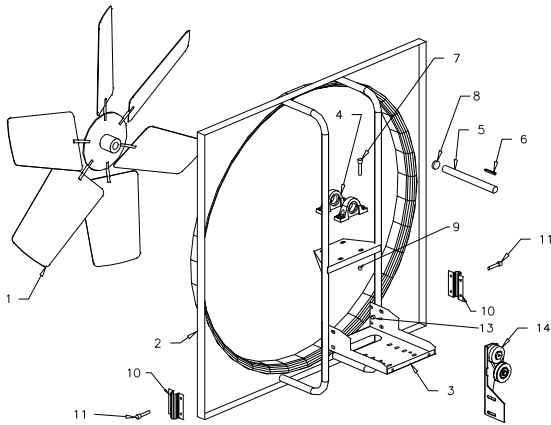

FIGURE 11.0.

**10.1. PROPELLER FAN ASSEMBLY**

For easier assembly it is advisable to install the sheave, pulley and belt before the unit is set over the roof opening.

1. Place the motor on the flat side of the adjustable motor base so that the drive belt will pass through the oblong cut out.
2. Adjust motor base as required to assure proper belt tension.



**Fan Assembly**

Ref. No.	Description	Qty
1	Fan propeller blade	1
2	Venturiframe assembly	1
3	Adjustable motor base	1
4	Bearing	2
5	Shaft	1
6	Shaft key	1
7	Bolt	4
8	Retaining Ring	1
9	Locknut	4
10	U clip	2
11	Bolt	8
12	N/A	0
13	Locknut	8
14	Automatic belt tensioner (optional)	1

**10.2. BLOWER FAN ASSEMBLY**

Motor location may vary by cooler model, but the same principles apply regarding belt alignment and adjustment.

1. Place the motor on the adjustable motor base - either pivot plate or manual slide rail.
2. Adjust motor as required to assure proper belt tension.



# THREE PHASE MOTOR DATA

MOTOR H.P.

FOR 60 Hz, 1800 RPM STANDARD SQUIRREL CAGE MOTORS (non Design E)		15	10	7	5	3	2	1	1		
FULL LOAD CURRENT (NEC)—AMPS		48.3	32.2	25.3	17.5	11.0	7.8	6.9	4.8	3.7	2.5
MINIMUM COPPER WIRE SIZE—(75) THW, THHN—THWN, XHHW—SIZE		6	8	10	12	14	14	14	14	14	14
CIRCUIT BREAKER	THERMAL-MAGNETIC BREAKER TRIP RATING—AMPS INDUSTRIAL BREAKER—CAT. NO. (breaker only)	FAL32090	FAL32060	FAL32050	FAL32035	FAL32020	FAL32015	FAL32015	FAL32015	FAL32015	FAL32015
FUSIBLE SWITCH	HEAVY DUTY SWITCH—NEMA 1 ENCL.—CAT. NO. WITH DUAL ELEMENT TIME DELAY FUSE—AMPS	H322N 60	H322N 50	H322N 40	H321N 25	H321N 17.5	H321N 10	H321N 8	H321N 6.25	H321N 4	H321N 4
MAGNETIC STARTER	NEMA 1 ENCL.—CLASS 8536 TYPE WITH THREE MELTING ALLOY THERMAL UNITS—NO	SEG-1 CC74.6	SDG-1 B56	SCG-3 B45	SCG-3 B28.0	SBG-2 B15.5	SBG-2 B11.5	SAG-12 B10.2	SAG-12 B6.90	SAG-12 B4.85	SAG-12 B3.30
FULL LOAD CURRENT (NEC)—AMPS		42	28	22	15.2	9.6	6.8	6.0	4.2	3.2	2.2
MINIMUM COPPER WIRE SIZE—(75) THW, THHN—THWN, XHHW—SIZE		6	10	10	14	14	14	14	14	14	14
CIRCUIT BREAKER	THERMAL-MAGNETIC BREAKER TRIP RATING—AMPS INDUSTRIAL BREAKER—CAT. NO. (breaker only)	FAL32080	FAL32060	FAL32045	FAL32030	FAL32020	FAL32015	FAL32015	FAL32015	FAL32015	FAL32015
FUSIBLE SWITCH	HEAVY DUTY SWITCH—NEMA 1 ENCL.—CAT. NO. WITH DUAL ELEMENT TIME DELAY FUSE—AMPS	H322N 60	H322N 40	H321N 30	H321N 25	H321N 15	H321N 10	H321N 8	H321N 5.6	H321N 4	H321N 4
MAGNETIC STARTER	NEMA 1 ENCL.—CLASS 8536 TYPE WITH THREE MELTING ALLOY THERMAL UNITS—NO	SDG-1 B79	SDG-1 B45	SCG-3 B36	SCG-3 B25	SBG-2 B14	SBG-2 B10.2	SAG-12 B9.10	SAG-12 B6.25	SAG-12 B4.15	SAG-12 B3.30
FULL LOAD CURRENT (NEC)—AMPS		21	14	11	7.6	4.8	3.4	3.0	2.1	1.6	1.1
MINIMUM COPPER WIRE SIZE—(75) THW, THHN—THWN, XHHW—SIZE		10	14	14	14	14	14	14	14	14	14
CIRCUIT BREAKER	THERMAL-MAGNETIC BREAKER TRIP RATING—AMPS INDUSTRIAL BREAKER—CAT. NO. (breaker only)	FAL34040	FAL34025	FAL34020	FAL34015	FAL34015	FAL34015	FAL34015	FAL34015	FAL34015	FAL34015
FUSIBLE SWITCH	HEAVY DUTY SWITCH—NEMA 1 ENCL.—CAT. NO. WITH DUAL ELEMENT TIME DELAY FUSE—AMPS	H361 30	H361 20	H361 20	H361 15	H361 8	H361 6.25	H361 5.6	H361 4	H361 3.2	H361 2
MAGNETIC STARTER	NEMA 1 ENCL.—CLASS 8536 TYPE WITH THREE MELTING ALLOY THERMAL UNITS—NO	SDG-1 B32	SCG-3 B25	SCG-3 B17.5	SBG-2 B11.5	SBG-2 B6.90	SAG-12 B4.85	SAG-12 B4.15	SAG-12 B3.00	SAG-12 B2.40	SAG-12 B1.45
FULL LOAD CURRENT (NEC)—AMPS		17	11	9.0	6.1	3.9	2.7	2.4	1.7	1.3	0.9
MINIMUM COPPER WIRE SIZE—(75) THW, THHN—THWN, XHHW—SIZE		12	14	14	14	14	14	14	14	14	14
CIRCUIT BREAKER	THERMAL-MAGNETIC BREAKER TRIP RATING—AMPS INDUSTRIAL BREAKER—CAT. NO. (breaker only)	FAL36035	FAL36020	FAL36015	FAL36015	FAL36015	FAL36015	FAL36015	FAL36015	FAL36015	FAL36015
FUSIBLE SWITCH	HEAVY DUTY SWITCH—NEMA 1 ENCL.—CAT. NO. WITH DUAL ELEMENT TIME DELAY FUSE—AMPS	H361 25	H361 20	H361 15	H361 10	H361 6.25	H361 5	H361 4	H361 3.2	H361 2.5	H361 1.8
MAGNETIC STARTER	NEMA 1 ENCL.—CLASS 8536 TYPE WITH THREE MELTING ALLOY THERMAL UNITS—NO	SDG-1 B25	SCG-3 B17.5	SCG-3 B12.8	SBG-2 B9.10	SBG-2 B4.85	SAG-12 B3.70	SAG-12 B3.30	SAG-12 B2.40	SAG-12 B1.88	SAG-12 B1.30

MOTOR SYSTEM  
200  
(208)  
VOLTS

MOTOR SYSTEM  
230  
(240)  
VOLTS

MOTOR SYSTEM  
460  
(480)  
VOLTS

MOTOR SYSTEM  
575  
(600)  
VOLTS



Full load currents, wire sizes, and switch sizes are based on 1990 NEC. Fuse sizes and circuit breaker trip amperes are appropriate selections, suitable for most installations. Thermal unit selections are not based on NEC currents (see NEC 430-6), but are selected from average full load currents. Thermal units can be more accurately selected using table furnished with starter and full load current marked on motor nameplate.

## WIRING INSTRUCTIONS

All units come supplied with pre-wired weather tight electric enclosure mounted on the inside of the unit. When wiring the unit from the factory installed electrical box to the outside of the unit, ALL grounding, wiring and materials must be installed in accordance with all current N.E.C. and local codes, and must be performed by a qualified licensed technician. Consult the chart below for proper wire, circuit breaker and fuseable switch. CAUTION: Improper wiring, installation or maintenance of equipment may cause electric shock, fire or injury to persons.

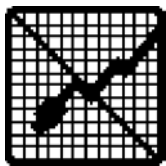

### SAFETY

Caution: DISCONNECT ALL ELECTRICAL POWER TO THE UNIT BEFORE ATTEMPTING TO INSTALL, OPEN, OR SERVICE YOUR UNIT.

IF THE UNIT IS THERMOSTATICALLY CONTROLLED, THE THERMOSTAT IS NOT TO BE USED AS A DISCONNECT AS IT MAY RESET AND START THE UNIT UNEXPECTEDLY.

Caution: Do not exceed the maximum amperage output as stamped on the motor specification plate or motor can overload. Only qualified persons with proper electrical equipment and knowledge should adjust variable pitch sheaves. Do not allow water to get in the motor.

Caution: Disconnect all the electrical power to the unit and insure that belt is not rotating before adjusting belt tension. Do not adjust belt tension by changing diameter of adjustable sheave. Adjust belt tension only by adjusting motor bracket.

Even while routinely inspecting or servicing the inside, the unit can be accidentally started. Keep children and pets away from the unit and electrical supply when you are working on it.

Do not attempt to perform any part of the installation described in this booklet unless you are FULLY QUALIFIED to do so. All electrical work must meet local codes and must be performed by qualified personnel only.

# RIGGING INSTRUCTIONS

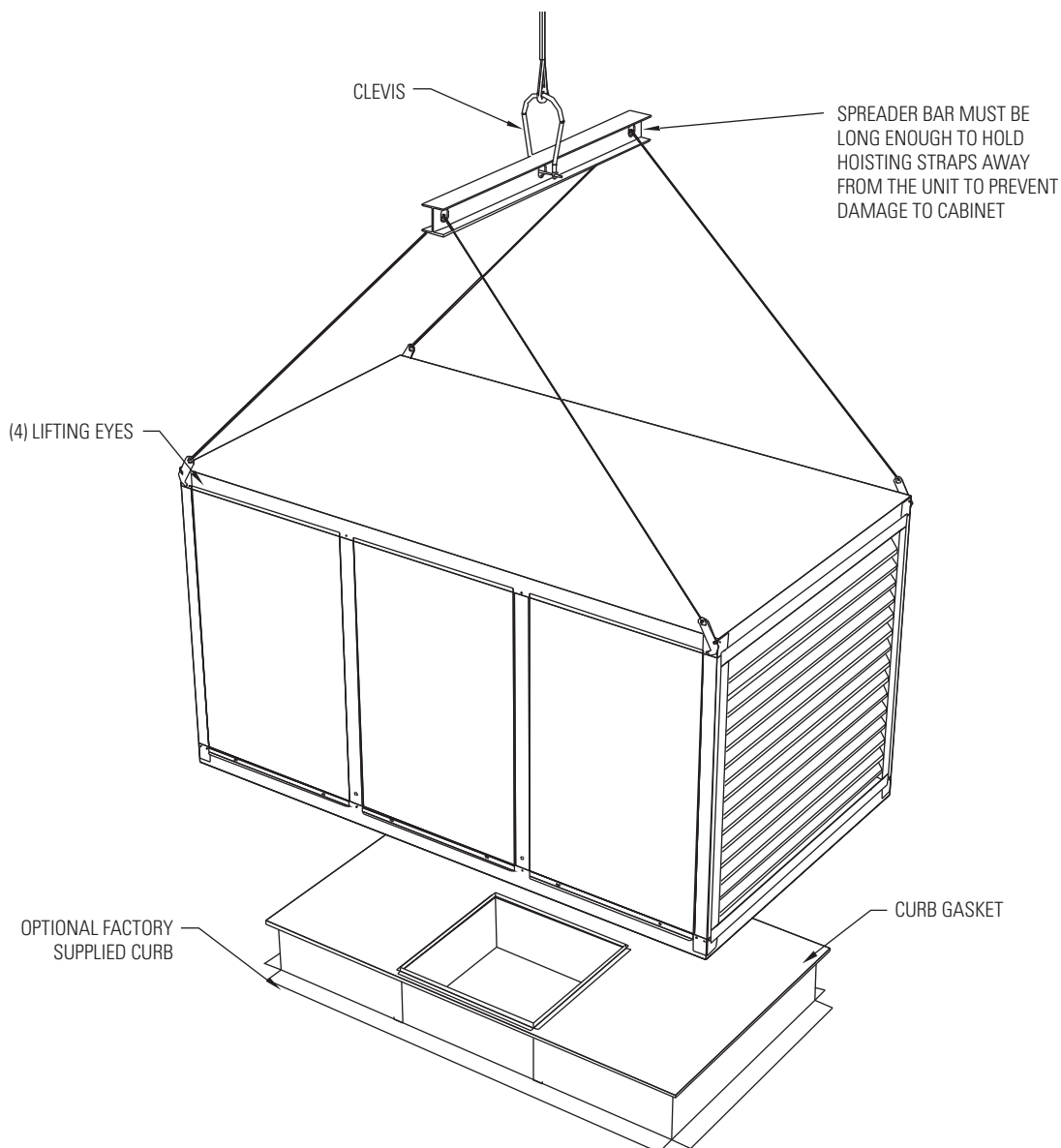

1. Avoid unnecessary jarring or rough handling.
2. Spreader bars must be used to prevent damage to the unit casing.
3. Care must be taken to keep the unit in the upright position during rigging.
4. Use lifting eyes provided on top of unit.
5. Avoid damage to the curb and curb gasket when rigging onto a curb.
6. Only used trained professional riggers when moving equipment.

Proper handling of the equipment is mandatory during unloading and setting it into position.

NOTE: If equipment is not set in its permanent position and is stored on the ground or other unlevel area, proper provisions

must be taken for supporting and protecting the equipment. See Long-Term Storage section on the Start-Up sheet.

It is mandatory that the proper spreader bars and hoisting straps be used when rigging. It is also mandatory that an experienced and reliable rigger be selected to handle unloading and final placement of the equipment. Your rigger must be advised that the unit contains delicate components and that it be handled in an upright position. Care must be exercised to avoid twisting the structure.

When the equipment has been set in final placement, the following must be done:

1. Remove any internal shipping blocks.
2. Tighten any bolts or screws that may have worked loose during shipment.

# TROUBLESHOOTING GUIDE

SYMPTOM	POSSIBLE CAUSES	CORRECTIVE ACTION
WATER CARRYOVER INTO AIR STREAM	<ol style="list-style-type: none"> <li>1. Air gaps between pads.</li> <li>2. Media installed backwards.</li> <li>3. Excessive fan RPM.</li> <li>4. Poor quality replacement media.</li> <li>5. Incorrectly sized replacement media.</li> <li>6. Excessive water flow.</li> <li>7. Plugged evaporative media.</li> <li>8. Heavy salt laden water.</li> </ol>	<ol style="list-style-type: none"> <li>1. Adjust evaporative pads sections to close air gaps.</li> <li>2. Remove and reinstall media with 45° angled flutes slanted toward entering air.</li> <li>3. Adjust fan RPM at adjustable motor sheave.</li> <li>4. Replace with high quality OE media or equal.</li> <li>5. Replace with correct size of media.</li> <li>6. Adjust inline valve provided on unit. Flow should not exceed 1.5 GPM per sq. ft. of top pad area.</li> <li>7. Rinse or replace pad.</li> <li>8. Wash media, drain and fill reservoir, and verify a sufficient bleed rate.</li> </ol>
EXCESSIVE NOISE AND/OR VIBRATION	<ol style="list-style-type: none"> <li>1. Defective bearing.</li> <li>2. Locking collar loose on shaft.</li> <li>3. Foreign material inside sealed bearing.</li> <li>4. Sheave not tightened on shaft: (motor or fan / blower).</li> <li>5. Loose fan / blower.</li> <li>6. Loose belt.</li> <li>7. Belts are worn, oily, or dirty.</li> <li>8. Improper drive selection.</li> <li>9. Misaligned sheaves.</li> <li>10. Fan / blower out of balance.</li> <li>11. Motor or motor base not securely anchored.</li> <li>12. Bent fan / blower shaft.</li> <li>13. Bearings dry.</li> <li>14. Fan / blower wheel rubbing on housing</li> </ol>	<ol style="list-style-type: none"> <li>1. Replace.</li> <li>2. Tighten screw.</li> <li>3. Replace.</li> <li>4. Tighten set screw and check alignment.</li> <li>5. Tighten bolts / screws.</li> <li>6. Adjust tension.</li> <li>7. Clean or replace.</li> <li>8. See cooler name plate for correct drive selection.</li> <li>9. Realign.</li> <li>10. Straighten or replace.</li> <li>11. Secure properly.</li> <li>12. Replace.</li> <li>13. Lubricate fan / blower bearings.</li> <li>14. Inspect fan / blower shaft collars, belt, pulley alignment, and motor mounting.</li> </ol>
FAN / BLOWER INOPERATIVE	<ol style="list-style-type: none"> <li>1. Blown fuse or open circuit breaker.</li> <li>2. Broken belt.</li> <li>3. Loose sheaves.</li> <li>4. Electricity turned off.</li> <li>5. Defective motor.</li> </ol>	<ol style="list-style-type: none"> <li>1. Replace fuse or reset circuit breaker.</li> <li>2. Replace.</li> <li>3. Tighten and check alignment.</li> <li>4. Contact local power company.</li> <li>5. Repair or replace.</li> </ol>
INSUFFICIENT AIR FLOW	<ol style="list-style-type: none"> <li>1. Lack of sufficient air exhaust.</li> <li>2. Fan / blower speed too slow (RPM).</li> <li>3. Belt slippage.</li> <li>4. Evaporative cooling media plugged.</li> <li>5. Inlet louver panel plugged.</li> </ol>	<ol style="list-style-type: none"> <li>1. Open window or doors to increase ventilation.</li> <li>2. Check for proper drive combination.</li> <li>3. Tighten and check alignment.</li> <li>4. Rinse or replace pad.</li> <li>5. Clean louver.</li> </ol>
INADEQUATE COOLING	<ol style="list-style-type: none"> <li>1. Insufficient water flow to pads, i.e. pads are dry.</li> <li>2. Pads plugged with scale.</li> <li>3. Dry media pads.</li> <li>4. Pump inoperative.</li> <li>5. Evaporative media installed backward.</li> <li>6. Distributor plugged.</li> <li>7. Water level too low in reservoir.</li> <li>8. No water supply.</li> <li>9. Low water pressure.</li> </ol>	<ol style="list-style-type: none"> <li>1. Check water distribution system.</li> <li>2. Rinse or replace media.</li> <li>3. Open inline ball valve to allow more flow.</li> <li>4. Unplug pump. Clean impeller housing.</li> <li>5. Reinstall media pads as shown above</li> <li>6. Clear holes or replace distributor system.</li> <li>7. Adjust water level to between 2 and 2 ½" . "</li> <li>8. Turn on water level.</li> <li>9. Increase to minimum of 50 p.s.i.</li> </ol>
MOTOR CYCLES ON AND OFF	<ol style="list-style-type: none"> <li>1. Excessive belt tension.</li> <li>2. Fan / blower shaft tight or frozen.</li> <li>3. Motor overloaded.</li> <li>4. Improper pulley sizing on fan unit.</li> </ol>	<ol style="list-style-type: none"> <li>1. Adjust belt tension.</li> <li>2. Lubricate fan / blower bearings.</li> <li>3. Adjust motor to name plate amps.</li> <li>4. Refer to cooling name plate for proper sizes.</li> </ol>
WATER DRIPPING FROM OVERFLOW STANDPIPE OF CORNER OF UNIT	<ol style="list-style-type: none"> <li>1. Float arm improperly adjusted.</li> <li>2. Float valve leaking.</li> <li>3. Unlevel mounting.</li> </ol>	<ol style="list-style-type: none"> <li>1. Adjust float.</li> <li>2. Replace float valve.</li> <li>3. Level the unit on the stand or roof curb.</li> </ol>
DISAGREEABLE ODOR	<ol style="list-style-type: none"> <li>1. Evaporative media not completely saturated.</li> <li>2. Stagnant or stale water in reservoir.</li> <li>3. Evaporative media mildewed or clogged.</li> </ol>	<ol style="list-style-type: none"> <li>1. Saturate evaporative media before starting unit.</li> <li>2. Drain, flush, and clean reservoir.</li> <li>3. Replace evaporative media.</li> </ol>

# LIMITED WARRANTY

UNITED METAL PRODUCTS, INCORPORATED extends this limited warranty to the original buyer and warrants that products manufactured by United Metal Products shall be free from original defects in workmanship and materials for one year from start-up or 18 months from date of shipment (whichever is sooner), provided same have been properly stored, installed, serviced, maintained and operated with bleed-off system properly installed. This warranty shall not apply to products which have been altered or repaired without United Metal Product's express authorization, or altered or repaired in any way so as, in United Metal Product's judgment, to affect its performance or reliability, nor which have been improperly installed or subjected to misuse, negligence, or accident, or incorrectly used in combination with other substances. Warranties on purchased parts, such as electric motors, pumps and pads, are limited to the terms of warranty extended by our supplier (usually one year duration).

**LIMITATION OF REMEDY AND DAMAGES:** All claims under this warranty must be made in writing and delivered to United Metal Products, Inc., 1920 East Encanto Drive, Tempe, Arizona 85281, within 15 days after the date of shipment by United Metal Products of the product claimed defective, and Buyer shall be barred from any remedy if Buyer fails to make such claim within such period.

Within 30 days after receipt of a timely claim, United Metal Products shall have the option either to inspect the product while in Buyer's possession or to request Buyer to return the product to United Metal Products at Buyer's expense for inspection by United Metal Products. United Metal Products shall replace, or at its option repair, free of charge, any product it determines to be defective, and it shall ship the repaired or replacement product to Buyer FOB. point of shipment; provided, however, if circumstances are such as in United Metal Products judgment to prohibit repair or replacement to remedy the warranted defects, the Buyer's sole and exclusive remedy shall be a refund to the Buyer of any part of the invoice

price, paid to United Metal Products, for the defective product or part.

United Metal Products is not responsible for the cost of removal of the defective product or part, damages due to removal, or any expenses incurred in shipping the product or part to or from United Metal Products plant, or the installation of the repaired or replaced product or part.

Implied warranties, when applicable, shall commence upon the same date as the express warranty provided above, and shall, except for warranties of title, extend only for the duration of the express warranty. Some States do not allow limitations on how long an implied warranty lasts, so the above limitation may not apply to you. The only remedy provided to you under an applicable implied warranty and the express warranty shall be the remedy provided under the express warranty, subject to the terms and conditions contained therein, United Metal Products shall not be liable for incidental and consequential losses and damages under the express warranty, any applicable implied warranty, or claims for negligence, except to the extent that this limitation is found to be unenforceable under applicable state law. Some states do not allow the exclusion or limitation of incidental or consequential damages, so the above limitation or exclusion may not apply to you. This warranty gives you specific legal rights, and you may also have other rights which vary from State to state.

No employee, agent, dealer, or other person is authorized to give any warranties on behalf of United Metal Products or to assume for United Metal Products any other liability in connection with any of its products except in writing and signed by an officer of United Metal Products. Liability shall in no case exceed the unit price of the defect product or part.

**TECHNICAL ADVICE AND RECOMMENDATIONS, DISCLAIMER:** Notwithstanding any past practice or dealings or any custom of the trade, sales shall not include the furnishing of technical advice or assistance or system design. Any such assistance shall be at United Metal Products' sole option.

---

## WARNING

Our products are designed and manufactured to provide performance, but they are not guaranteed to be 100% free of defects. Even reliable products will experience occasional failure, and this possibility should be recognized by the User. If these products are used in a life support ventilation system where failure could result in loss or injury, the use should provide adequate back-up ventilation, supplementary natural ventilation or failure alarm system, or acknowledge willingness to accept the risk of such loss or injury.

**DO NOT USE IN HAZARDOUS ENVIRONMENTS** where fan's electrical system could provide ignition to combustible or flammable materials.

## NOTE

If any assistance from the factory is needed to check, test, or start-up any UMP equipment, a prevalent rate per day, per

person plus travel, lodging, food, etc., will be paid by the buyer/contractor.

## CAUTION

Guards must be installed when fan is within reach of personnel or within seven (7) feet of working level or when deemed advisable for safety.

## DISCLAIMER

United Metal Products, Inc. had made a diligent effort to illustrate and describe the products in this literature accurately; however, such illustrations and descriptions are for the sole purpose of identification, and do not express or imply a warranty that the products are merchantable, or fit for a particular purpose, or that the products will necessarily conform to the illustrations or descriptions or dimension.

All information in this literature is subject to change without notice.