

- *500 to 5,500 CFM @ up to 6.00" TSP*
- *2" and 4" double wall construction, perforated or solid lined*
- *18 gauge G90 galvanized steel cabinet*
- *18 standard cabinet sizes available*
- *Internally isolated direct drive plug fan*
- *ETL listed and labeled*

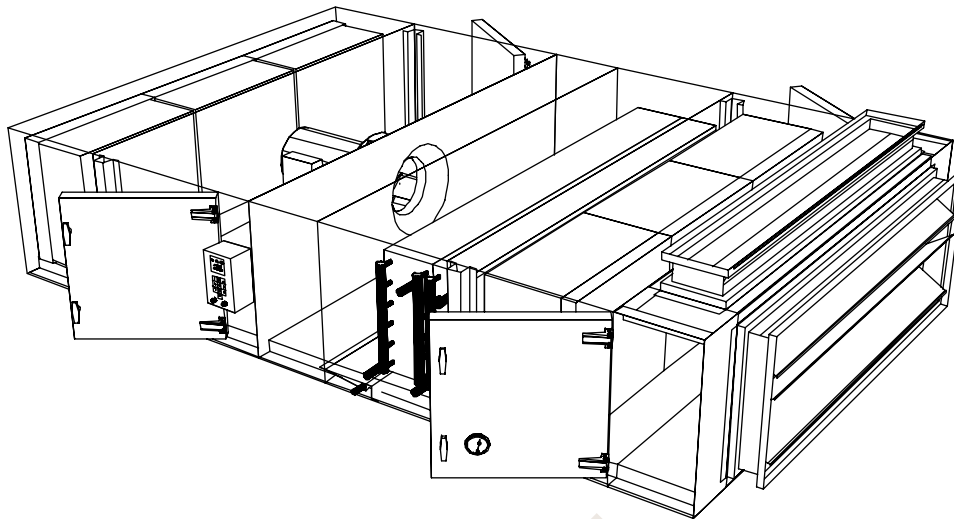

## High Quality, High Performance Small Air Handling Units 500 to 5,500 CFM @ up to 6.00" TSP.

### Why the MAH?

United Metal Products' MAH line of Air Handling Units offers a high quality, high performance, low maintenance and cost effective small air handling unit. The product is designed with a series of standard features typically found on higher quality, larger custom air handling units.

- Very quiet operation thanks to the direct drive plug fan, even in higher static pressure applications.
- Low profile design.
- Zero maintenance direct drive fans with no belts or bearings, and motors with permanently lubricated sealed bearings.
- #304 SS double sloped drain pans.
- High efficiency filtration for maximum indoor air quality.
- No need for external isolators thanks to the internal isolation under the fan and motor.
- Suitable for Mixed Air, 100% RA, 100% OSA, or economizer applications.

### Applications:

The MAHs have been designed for those applications where the high quality components of an air handling unit are required along with a fan and cabinet that can produce high static pressures in the low-profile format of a traditional fan coil unit. The modular construction, 2" or 4" double wall cabinet, component options, speed control and vibration isolation all contribute to make the United Metal Products MAH suitable for applications including:

- Hospitals
- Museums
- Pharmaceutical Laboratories
- High tech manufacturing
- Clean rooms
- Schools & Colleges
- Commercial
- Institutional
- Other acoustically or IAQ sensitive applications

### Resources Available for This Product

- Catalog By Mail
- Catalog Online



### United Metal Products

1920 E Broadway Road Tempe, AZ 85282  
T 480.968.9550  
F 480.968.9555