

## **Roof-Top Power Ventilators & Fresh Air Intakes For Commercial, Industrial and Agricultural Requirements**

### **Features:**

- Factory tested and shipped ready to operate, including factory wired components
- ETL listed and labeled in accordance with U.L. standards
- Copper-wound heavy duty ball bearing motors
- Self-aligning, heavy duty, greaseable, pillow block, ball type fan bearing
- Aluminum Construction with Key Steel Components
- Adjustable motor sheave for air flow adjustment
- Lifting sky hooks
- The most up-to-date propeller type axial fan affords maximum air delivery while minimizing horsepower
- Interchangeable components with UMP-700 Series evaporative coolers
- Tilting hinged access hood for ease of maintenance
- 1/4" by 1/4" Birdscreen

### **• UE Series**

- *Exhaust / Intake*
  - UE 30
  - UE 36
  - UE 42
  - UE 48
  - UE 48-2

### **Available Options**

- Pre-wired control packages
- Spark resistant fans
- Explosion proof motors
- Self-tensioning belt
- Installation accessories
- Back draft damper
- Safety guards
- Fused and non-fused disconnects

### **Resources Available for This Product**

- Catalog By Mail
- Catalog Online



### **United Metal Products**

1920 E Broadway Road Tempe, AZ 85282  
 T 480.968.9550  
 F 480.968.9555  
[www.unitedmetal.com](http://www.unitedmetal.com)

| Model                                | AIR DELIVERY IN CUBIC FEET PER MINUTE |     |        |     |        |     |        |     | ELECTRICAL SPECIFICATIONS |          |  |  | FAN UNIT                               |  |         |         | Dimensions (inches) |       |       |        |    |     | Weights (Lbs) <sup>②</sup> |      |     |
|--------------------------------------|---------------------------------------|-----|--------|-----|--------|-----|--------|-----|---------------------------|----------|--|--|--|--|---------|---------|---------------------|-------|-------|--------|----|-----|----------------------------|------|-----|
|                                      | Inches Static Pressure (W.G.)         |     |        |     |        |     |        |     | Fan Motor <sup>①</sup>    |          |  |  | Fan                                    |  | Drives  |         |                     |       |       |        |    |     |                            |      |     |
|                                      | Free Air                              |     | 0.125  |     | 0.25   |     | 0.375  |     | HP                        | Max BHP  | Volt/Phase 115/208/230<br>1-Phase Amps |  | Volt/Phase 208/230/460<br>3-Phase Amps |  | Dia.    | Max RPM | Belt                | Shaft | A     | B      | C  | D   |                            | E    | F   |
|                                      | CFM                                   | RPM | CFM    | RPM | CFM    | RPM | CFM    | RPM |                           |          |  |  |  |  |         |         |                     |       |       |        |    |     |                            |      |     |
| UE 30<br>Exhaust (E)<br>Intake (I)   | 9,330                                 | 676 | 8,080  | 676 | 3,570  | 676 | --     | --  | 1/2                       | .57      | 9.8/5.4/4.9                            |  | 2.4/2.2/1.1                            |  | 30"     | 800     | A40                 | 1"    | 33.75 | 33.75  | 60 | 68  | 18.00                      | 32.5 | 249 |
|                                      | 10,650                                | 771 | 9,610  | 771 | 7,710  | 771 | 5,150  | 771 | 3/4                       | .86      | 13.8/7.6/6.9                           |  | 3.5/3.2/1.6                            |  | 30"     | 800     | A40                 | 1"    | 33.75 | 33.75  | 60 | 68  | 18.00                      | 32.5 | 257 |
|                                      | 11,720                                | 849 | 10,800 | 849 | 9,490  | 849 | 6,960  | 849 | 1                         | 1.15     | 16.0/8.8/8.0                           |  | 4.6/4.2/2.1                            |  | 30"     | 800     | A40                 | 1"    | 33.75 | 33.75  | 60 | 68  | 18.00                      | 32.5 | 259 |
| UE 36<br>Exhaust (E)<br>Intake (I)   | 12,550                                | 550 | 10,870 | 550 | 7,360  | 550 | --     | --  | 3/4                       | 0.86     | 13.8/7.6/6.9                           |  | 3.5/3.2/1.6                            |  | 36"     | 800     | A44                 | 1"    | 39.75 | 39.75  | 78 | 80  | 18.00                      | 32.5 | 299 |
|                                      | 13,830                                | 610 | 12,330 | 610 | 9,980  | 610 | --     | --  | 1                         | 1.15     | 16.0/8.8/8.0                           |  | 4.6/4.2/2.1                            |  | 36"     | 800     | A44                 | 1"    | 39.75 | 39.75  | 78 | 80  | 18.00                      | 32.5 | 300 |
|                                      | 15,610                                | 680 | 14,300 | 680 | 12,770 | 680 | 9,350  | 680 | 1 1/2                     | 1.73     | 20.0/11.0/10.0                         |  | 6.6/6.0/3.0                            |  | 36"     | 800     | A44                 | 1"    | 39.75 | 39.75  | 78 | 80  | 18.00                      | 32.5 | 312 |
| UE 42<br>Exhaust (E)<br>Intake (I)   | 16,890                                | 470 | 14,610 | 470 | 9,840  | 470 | --     | --  | 1                         | 1.15     | 16.0/8.8/8.0                           |  | 4.6/4.2/2.1                            |  | 42"     | 690     | A48                 | 1"    | 45.75 | 45.75  | 90 | 80  | 18.00                      | 32.5 | 339 |
|                                      | 19,070                                | 530 | 17,100 | 530 | 14,260 | 530 | --     | --  | 1 1/2                     | 1.73     | 20.0/11.0/10.0                         |  | 6.6/6.0/3.0                            |  | 42"     | 690     | A48                 | 1"    | 45.75 | 45.75  | 90 | 80  | 18.00                      | 32.5 | 351 |
|                                      | 20,970                                | 580 | 19,190 | 580 | 17,100 | 580 | 12,460 | 580 | 2                         | 2.3      | 24.0/13.2/12.0                         |  | 7.5/6.8/3.4                            |  | 42"     | 690     | A48                 | 1"    | 45.75 | 45.75  | 90 | 80  | 18.00                      | 32.5 | 371 |
| UE 48<br>Exhaust (E)<br>Intake (I)   | 22,710                                | 430 | 19,850 | 430 | 13,880 | 430 | --     | --  | 1 1/2                     | 1.73     | 20.0/11.0/10.0                         |  | 6.6/6.0/3.0                            |  | 48"     | 630     | A60                 | 1"    | 53.75 | 53.75  | 98 | 92  | 18.00                      | 32.5 | 400 |
|                                      | 25,050                                | 470 | 22,500 | 470 | 18,940 | 470 | --     | --  | 2                         | 2.3      | 24.0/13.2/12.0                         |  | 7.5/6.8/3.4                            |  | 48"     | 630     | A60                 | 1"    | 53.75 | 53.75  | 98 | 92  | 18.00                      | 32.5 | 420 |
|                                      | 28,620                                | 540 | 26,410 | 540 | 23,930 | 540 | 18,630 | 540 | 3                         | 3.45     | -- /18.7/17.0                          |  | 10.6/9.6/4.8                           |  | 48"     | 630     | A60                 | 1"    | 53.75 | 53.75  | 98 | 92  | 18.00                      | 32.5 | 432 |
| UE 48-2<br>Exhaust (E)<br>Intake (I) | 45,420                                | 430 | 39,700 | 430 | 27,760 | 430 | --     | --  | (2) 1 1/2                 | (2) 1.73 | (2) 20.0/11.0/10.0                     |  | (2) 6.6/6.0/3.0                        |  | (2) 48" | 630     | A60                 | 1"    | 53.75 | 107.75 | 98 | 148 | 18.00                      | 32.5 | 668 |
|                                      | 50,100                                | 470 | 45,000 | 470 | 37,880 | 470 | --     | --  | (2) 2                     | (2) 2.3  | (2) 24.0/13.2/12.0                     |  | (2) 7.5/6.8/3.4                        |  | (2) 48" | 630     | A60                 | 1"    | 53.75 | 107.75 | 98 | 148 | 18.00                      | 32.5 | 708 |
|                                      | 57,240                                | 540 | 52,820 | 540 | 47,860 | 540 | 37,260 | 540 | (2) 3                     | (2) 3.45 | (2) -- /18.7/17.0                      |  | (2) 10.6/9.6/4.8                       |  | (2) 48" | 630     | A60                 | 1"    | 53.75 | 107.75 | 98 | 148 | 18.00                      | 32.5 | 732 |

\* Performance ratings shown does not include drive losses or system effect. Consider a minimum of 0.125" pressure on all systems.  
 \* Performance shown is for installation Type A: Free Inlet, Free Outlet.  
 \* Power rating (BHP) does not include drive losses.

- ① Only motors 1 HP or less are provided with integral thermal protection. Motors 1.5 HP or greater require a separate motor overload device. Amperage ratings shown are NEC at nominal HP. Usable at 208v. Consult factory for overload and control options.
- ② Weights are in pounds and include motors, belts, and drives. Weights exclude optional accessories such as curb, damper and controls.
- ③ Electrical Connects are centered on the motor side by default.

**CAUTION:** Do not use in hazardous environments where the fan's electrical system could provide ignition to combustible or flammable materials, unless unit is specifically built for hazardous environments.

**WARNING:** Guards must be installed when fan is within reach of personnel or within seven (7) feet of working level or when deemed advisable for safety.

End View

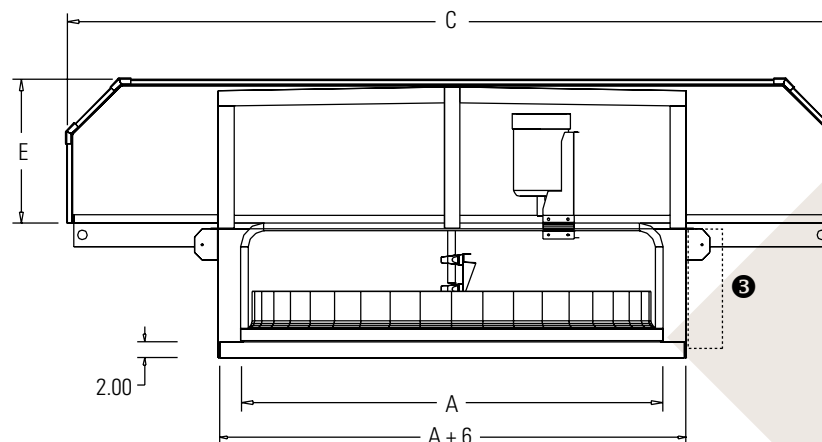

Side View

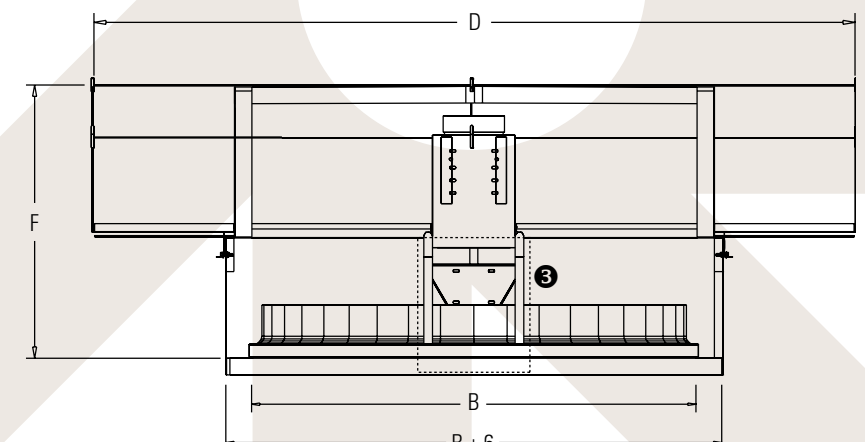

### UE Optional Accessories

| Description      | Part # | A      | B       | Weight in lbs. |
|------------------|--------|--------|---------|----------------|
| UE30 Roof Curb   | 81225  | 34.25" | 34.25"  | 45             |
| UE36 Roof Curb   | 65651  | 40.25" | 40.25"  | 55             |
| UE42 Roof Curb   | 65652  | 46.25" | 46.25"  | 65             |
| UE48 Roof Curb   | 65653  | 54.25" | 54.25"  | 75             |
| UE48-2 Roof Curb | 65654  | 54.25" | 108.25" | 110            |

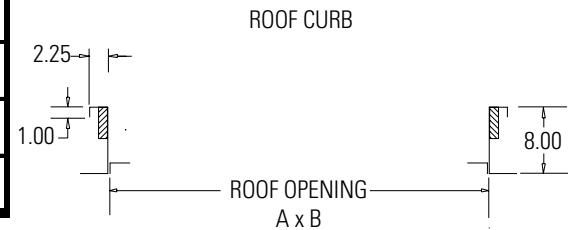

| Description           | Part # | A      | B       | Weight in lbs. |
|-----------------------|--------|--------|---------|----------------|
| UE30 Gravity Damper   | 73037  | 34.00" | 34.00"  | 23             |
| UE36 Gravity Damper   | 65750  | 40.00" | 40.00"  | 27             |
| UE42 Gravity Damper   | 65751  | 46.00" | 46.00"  | 29             |
| UE48 Gravity Damper   | 65752  | 54.00" | 54.00"  | 37             |
| UE48-2 Gravity Damper | 65753  | 54.00" | 108.00" | 73             |

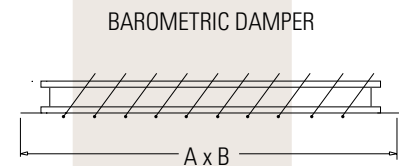

| Description             | Part #    | A      | B      | Weight in lbs. |
|-------------------------|-----------|--------|--------|----------------|
| UE30 Safety Grill       | 70666     | 33.00" | 33.00" | 9              |
| UE36 Safety Grill       | 52115     | 39.00" | 39.00" | 11             |
| UE42 Safety Grill       | 52116     | 45.00" | 45.00" | 14             |
| UE48 Safety Grill       | 52117     | 51.00" | 51.00" | 18             |
| (2) UE48-2 Safety Grill | (2) 52117 | 51.00" | 51.00" | (2) 18         |

