

- **700 Series - "Low Profile"**
- **UMP-730**  
-Down Discharge



## **Low Profile, High Capacity, High Efficiency Evaporative Cooling 14,000 to 21,000 CFM Industry Standard Rating**

### **Features**

- "Low profile" (only 38.25" high)
- Factory tested and shipped ready to operate, including factory wired components
- ETL Listed and labeled in accordance with U.L. standards
- Copper-wound, heavy duty ball bearing motors
- One high capacity pump provides complete media saturation
- Self-aligning, heavy duty, greaseable, pillow block, ball type fan bearings
- Fan performance is factory set to job specific specifications
- Premium 8" thick cross fluted 80% efficient media
- Lifting sky hooks
- The most up-to-date propeller type axial fan affords maximum air delivery while minimizing horsepower
- Heavy gauge, hot dipped galvanized steel construction
- Epoxy powder base paint finish baked on at 375°
- Rugged cabinet assembly with double thick steel corners
- "Rain-Tight" pitched top construction (1/4"/12")
- Easily accessible external distributor clean-outs
- Side access media removal
- Adjustable motor sheave for air flow adjustment

### **Available Options**

- Class II, U.L. 900 media
- Prewired control packages
- Distribution flush system
- Freeze protection
- Hinged access door
- Self-tensioning belt
- Installation accessories
- Fused and non-fused disconnects

### **Resources Available for This Product**

- Catalog By Mail
- Catalog Online



*Patent #4774030 or other patents pending*

### **United Metal Products**

1920 E Encanto Drive Tempe, AZ 85281

T 480.968.9550

F 480.968.9555

[www.unitedmetal.com](http://www.unitedmetal.com)



Model	Industry Standard Rating	Inlet Type ⑥	AMCA LICENSED AIR DELIVERY IN CUBIC FEET PER MINUTE										ELECTRICAL SPECIFICATIONS					FAN UNIT		Evaporative Media	Weights (Lbs) ③		
			Inches Static Pressure (W.G.) ①										Fan Motor ②				Pump ⑤	Fan		Qty.-Depth x Width x Height	Shipping	Operate	
			0		0.1		0.2		0.3		0.4		HP	Max BHP	Volt/Phase 115/208/230 1-Phase Amps	Volt/Phase 208/230/460 3-Phase Amps	GPH @ 5' Head	Volt/Phase 115/ 1-Phase Amps	Dia.				Max RPM
UMP-730 Down	14,000	Louvered	11,071	404	9,343	405	7,364	409	4,778	398	----	---	3/4	0.86	13.8/7.6/6.9	3.5/3.2/1.6	820	2.3	42"	1,000	10 - 8" x 12" x 30"	608	949
		Wire Grill	12,975	408	10,930	405	8,525	409	5,650	403	----	---	3/4	0.86	13.8/7.6/6.9	3.5/3.2/1.6	820	2.3	42"	1,000	10 - 8" x 12" x 30"	598	939
	16,000	Louvered	12,175	445	10,656	446	8,929	450	6,842	449	4,219	434	1	1.15	16.0/8.8/8.0	4.6/4.2/2.1	820	2.3	42"	1,000	10 - 8" x 12" x 30"	611	952
		Wire Grill	14,236	449	12,438	445	10,292	447	7,876	452	4,517	436	1	1.15	16.0/8.8/8.0	4.6/4.2/2.1	820	2.3	42"	1,000	10 - 8" x 12" x 30"	601	942
	18,000	Louvered	13,909	509	12,610	509	11,182	513	9,571	516	7,623	513	1 1/2	1.73	20.0/11.0/10.0	6.6/6.0/3.0	820	2.3	42"	1,000	10 - 8" x 12" x 30"	621	962
		Wire Grill	16,281	515	14,734	510	13,000	511	11,047	514	8,844	518	1 1/2	1.73	20.0/11.0/10.0	6.6/6.0/3.0	820	2.3	42"	1,000	10 - 8" x 12" x 30"	611	952
21,000	Louvered	15,322	560	14,136	561	12,864	564	11,492	566	9,932	568	2	2.3	24.0/13.2/12.0	7.5/6.8/3.4	820	2.3	42"	1,000	10 - 8" x 12" x 30"	641	982	
	Wire Grill	17,252	545	15,801	541	14,752	554	13,385	563	11,522	568	2	2.3	24.0/13.2/12.0	7.5/6.8/3.4	820	2.3	42"	1,000	10 - 8" x 12" x 30"	631	972	

\* Performance rating include the effects of the evaporative media, inlet device (louver or grill), motor and drives in the airstream.  
 \* Performance certified is for installation Type B: Free Inlet, Ducted Outlet  
 \* Power rating (BHP) does not include transmission losses.

- ① The 700 series fan type evaporative coolers are only designed for straight down ducted applications. External static pressure ranges of 0.0" to 0.2". Higher ESP are only shown to demonstrate fan characteristics and performance with loaded media. For ducted applications with external static pressures exceeding 0.2" a UMP - 900 series blower model is recommended.
- ② Only motors 1 HP or less are provided with integral thermal protection. Motors 1.5 HP or greater require a separate motor overload device. Amperage ratings shown are NEC at nominal HP. Usable at 208v. Consult factory for overload and control options.
- ③ Weights are in pounds and include motors, pumps and drives. Operating weights include saturated media and assumes 2.5" depth of water in sump. Weights exclude optional accessories such as curb, diffuser and controls.
- ④ Minimum duct sizing should equal discharge dimension. Evaporative cooling is an adiabatic process. Possibility of water damage may exist. Special consideration must be taken when utilizing an evaporative cooler. Consult factory for special applications.
- ⑤ 230v pumps are available; contact UMP for details.
- ⑥ Model # UMP-730 is available with either an inlet louver or inlet grill. An inlet louver is recommended to protect the evaporative media from outdoor elements such as UV exposure, birds & storm damage. An inlet grill may be used in applications where a greater air volume is required but may shorten media life.



United Metal Products certifies that the Fan Air™ unit shown hereon is licensed to bear the AMCA Seal. The ratings shown are based on tests and procedures performed in accordance with AMCA Publication 211 and comply with the requirements of the AMCA Certified Ratings Program.



Manufacturer of Quality Air Moving Equipment

Top View

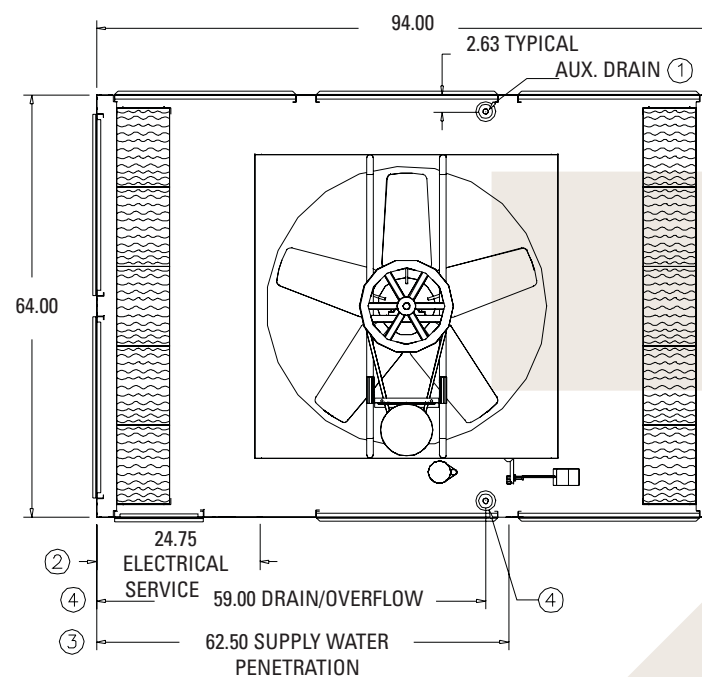

End View

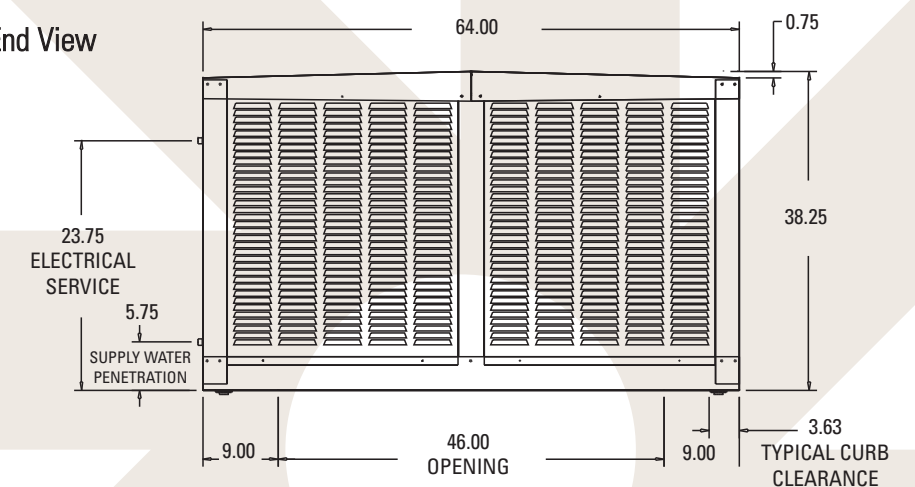

Side View

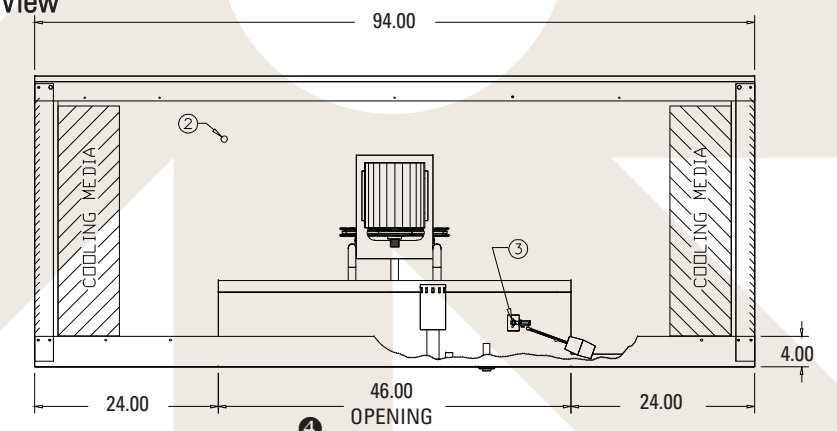

- ① Auxiliary drain utilized only with optional freeze protection or distribution flush system. Consult factory for special applications.
- ② 7/8" Electrical service entrance for 1/2" conduit.
- ③ 3/8" Compression fitting connection made inside unit. Minimum 30 p.s.i. water pressure is recommended to deliver the volume needed to meet high summer evaporation and bleed requirements. Do not exceed 125 p.s.i.
- ④ 3/4" Male hose thread.

Information subject to change. Updates available online.  
 FanAir/UMP-730/DIM/April 2011



### UMP-730 Optional Accessories

Description	Part #	Material / Finish	Roof Opening	Weight in Lbs.
UMP-730 Adj. Curb	7220-46	18 ga galv.	46" x 46"	60
Curb Tie-Down Kit	12434	16 ga painted galv.	--	4

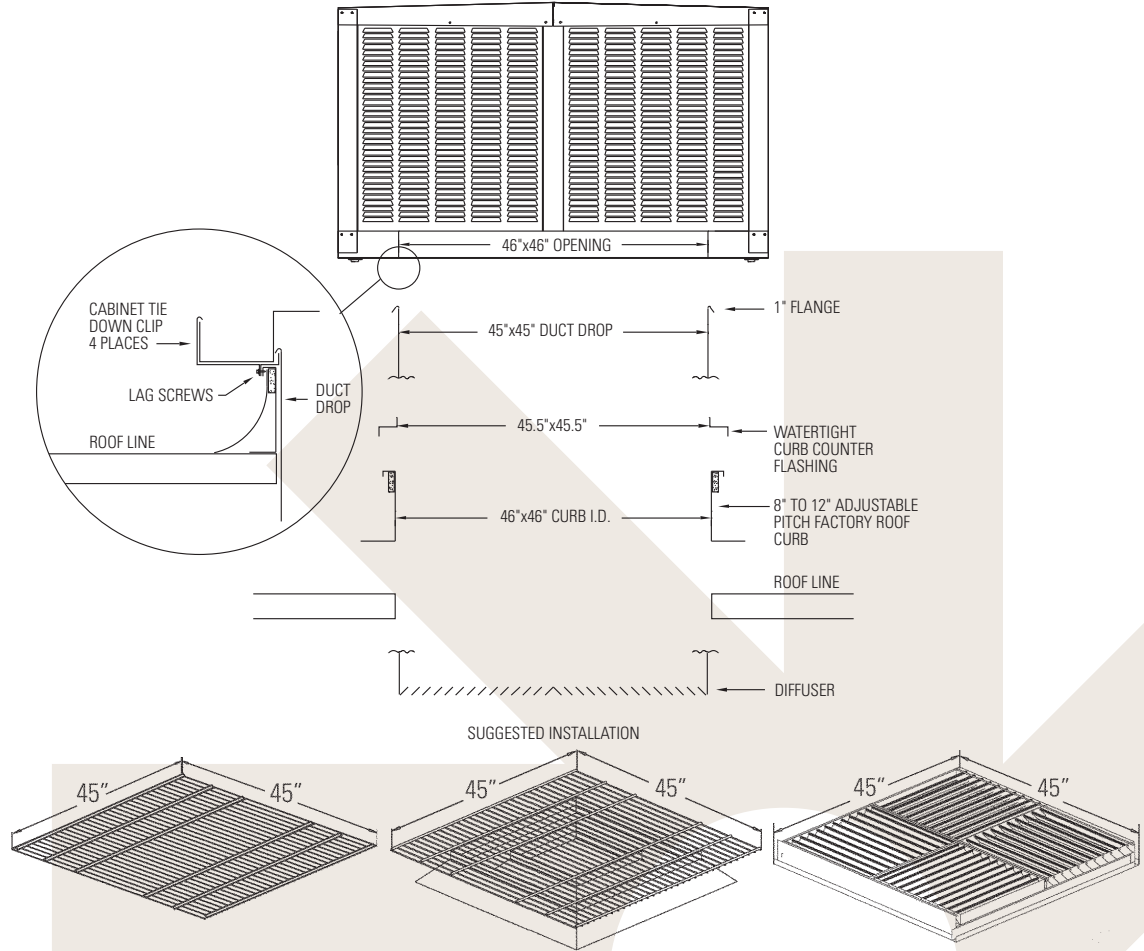

Description	UFG45 Grill	UFD45-2 Grill Diffuser	A4545 Auto Damper Diff.
Discharge Height Application	16' and above	12' to 16'	12' to 16'
Part #	10604	80284	20038
Pressure Drop @ 1,200 FPM	.02"	.07"	.10"
Material / Finish	CRS Grill / Gray	CRS Grill + Galv. Blades / Beige	CRS Grill + Aluminum / Gray
Weight in Lbs.	14	29	59

**CAUTION** - Guards must be installed when fan is delivering air over an occupied space, or when deemed advisable for safety. UMP diffusers feature a "safety guard" design. FAN-AIR coolers will not be provided without a diffuser or grille.

