

- *Double Inlet / Single Fan*



***Double Inlet/Single Fan—Industrial Class Evaporative Cooling Equipment with Capacities of 30,000 CFM to 80,000 CFM and up to 1.5" ESP or higher if required***

**Why?**

Cel-Air® units are high capacity, high efficiency evaporative cooling equipment. With 24 cataloged units and sizes ranging from 6,000 CFM to over 100,000 CFM, United Metal Products gives the engineer, contractor, or owner the choice and options they want.

**Benefits:**

- 24 cataloged sizes
- 2" double wall or single wall construction
- Galvanized, aluminum, stainless steel
- 6,000–100,000 CFM and above
- Evaporative cooling
- Forward curve, airfoil, or backward inclined wheels
- ETL labeling available
- Powder coated
- Stainless steel reservoir available

**Applications:**

- Aircraft hangars
- Clean room M.U.A.
- Data centers
- Food processing plants
- Gymnasiums
- Hospitals
- Kitchens
- Make up air requirement
- Manufacturing facilities
- Military bases
- Mining industry
- Municipalities
- Prisons
- Process cooling
- Schools
- Textile industries
- Turbine inlet cooling
- Waste water treatment facility
- Warehouses

**Resources Available for This Product**

- Catalog By Mail
- Catalog Online



**United Metal Products**

1920 E Encanto Drive Tempe, AZ 85281  
T 480.968.9550  
F 480.968.9555  
[www.unitedmetal.com](http://www.unitedmetal.com)



MODEL # Air Volume		DOUBLE INLET / SINGLE FAN - EXTERNAL STATIC PRESSURE ("WG)														Power Requirements (at 460/3/60) *			
		WITHOUT FILTERS		0.25		0.50		0.75		1.00		1.25		1.50		1.75		MCA Amps	MOP Amps
		WITH FILTERS		0.00		0.25		0.50		0.75		1.00		1.25		1.50			
		FAN	HP	FAN	HP	FAN	HP	FAN	HP	FAN	HP	FAN	HP	FAN	HP	FAN	HP		
CEL-ODO-60 30,000 cfm	DWDI FC	32	15	32	15	32	20	32	20	32	20	32	25	32	25	47	50		
	DWDI BI	40	10	40	15	40	15	40	15	40	15	40	20	40	20	39	40		
	DWDI AF							40	15	40	15	40	20	40	20	39	40		
CEL-ODO-72 36,000 cfm	DWDI FC	40	15	40	15	40	20	40	20	40	20	40	25	40	25	47	50		
	DWDI BI	40	15	40	15	40	20	40	20	40	20	40	25	40	25	47	50		
	DWDI AF													40	25	47	50		
CEL-ODO-84 42,000 cfm	DWDI FC	40	20	40	20	40	25	40	25	40	25	40	30	40	30	55	60		
	DWDI BI	40	20	40	20	40	25	40	25	40	25	40	30	40	30	55	60		
	DWDI AF																		
CEL-ODO-96 48,000 cfm	DWDI FC	40	25	40	25	40	30	40	30	40	40	40	40	40	40	70	80		
	DWDI BI	40	30	40	30	40	30	40	40	40	40	40	40	40	40	70	80		
	DWDI AF	36	30	36	30	36	40	36	40	36	40	36	40	36	40	70	80		
CEL-ODO-112 56,000 cfm	DWDI FC	40	40	40	40	40	50	40	50	40	50	40	50	40	60	101	125		
	DWDI BI	40	50	40	50	40	50	40	50	40	50	40	60	36	75	117	125		
	DWDI AF	40	30	40	40	40	40	40	40	40	40	40	50	40	50	86	90		
CEL-ODO-140 70,000 cfm	DWDI FC																		
	DWDI BI	49	40	49	40	49	40	49	50	49	50	49	50	49	50	86	90		
	DWDI AF	49	40	49	40	49	40	49	40	49	40	49	50	49	50	86	90		
CEL-ODO-160 80,000 cfm	DWDI FC																		
	DWDI BI	49	50	49	60	49	60	49	60	49	75	49	75	49	75	117	125		
	DWDI AF	49	50	49	50	49	50	49	60	49	60	49	60	49	60	102	125		

- \* Unit power requirements, dimensions and weights are given as a guide. They include down discharge AF fans and the largest motor HP shown. Motors are standard efficiency single speed ODP.
- \* Different fan or motor types, fan orientation or motor position will effect dimensions and weights. Full details will be given with any quotation.
- \* All these units can operate at higher static pressures with fan or motor changes. Please contact the factory with your requirements.
- \* Data is based on the maximum output of each unit size. Intermediate volumes will be achieved by reducing the fan speed.
- \* Data shown is based at sea level. HP and performance may be effected at high altitudes.
- \* The filter is an option. When adding filters, add the filter pressure drop to the unit ESP and use that total to select the motor HP.
- \* Please specify the fan discharge location (Up, Down or End) when ordering these units.



		DOUBLE INLET / SINGLE FAN - EVAPORATIVE COOLER DIMENSIONS - See Drawing										WEIGHTS	
MODEL # Air Volume	FAN QTY & TYPE	WIDTH	HEIGHT	LENGTH	A	B	C	D	E1	E2	F	With Clean Filters Ship Operate lb lb	
CEL-ODO-60 30,000 cfm	DWDI FC	102	93	182	6	23.9	39.7	39.7	71.2	71.2	31.6	5,275	6,225
	DWDI BI	102	93	182	6	27.0	49.9	49.9	66.1	66.1	34.8	5,575	6,550
	DWDI AF	102	93	182	6	27.0	49.9	49.9	66.1	66.1	34.8	5,550	6,500
CEL-ODO-72 36,000 cfm	DWDI FC	107	96	182	6	27.0	49.9	49.9	66.1	66.1	34.8	5,800	6,800
	DWDI BI	107	96	182	6	27.0	49.9	49.9	66.1	66.1	34.8	5,900	6,925
	DWDI AF	107	96	182	6	27.0	49.9	49.9	66.1	66.1	34.8	5,925	6,925
CEL-ODO-84 42,000 cfm	DWDI FC	107	96	182	6	27.0	49.9	49.9	66.1	66.1	34.8	5,875	7,050
	DWDI BI	107	96	182	6	27.0	49.9	49.9	66.1	66.1	34.8	5,975	7,125
	DWDI AF												
CEL-ODO-96 48,000 cfm	DWDI FC	110	96	182	6	27.0	49.9	49.9	66.1	66.1	34.8	6,075	7,400
	DWDI BI	110	96	182	6	27.0	49.9	49.9	66.1	66.1	34.8	6,150	7,475
	DWDI AF	110	96	182	6	35.2	51.8	38.7	65.1	65.1	37.2	6,850	8,175
CEL-ODO-112 56,000 cfm	DWDI FC	114	108	192	6	27.0	49.9	49.9	71.1	71.1	36.8	6,900	8,275
	DWDI BI	114	108	192	6	26.1	49.9	49.9	71.1	71.1	35.9	6,800	8,200
	DWDI AF	114	108	192	6	38.0	57.2	42.6	67.4	67.4	46.7	7,775	9,150
CEL-ODO-140 70,000 cfm	DWDI FC												
	DWDI BI	132	112	209	6	45.1	69.4	51.9	69.8	69.8	52.7	9,550	11,250
	DWDI AF	132	112	209	6	45.1	69.4	51.9	69.8	69.8	52.7	9,550	11,250
CEL-ODO-160 80,000 cfm	DWDI FC												
	DWDI BI	133	120	209	6	45.1	69.4	51.9	69.8	69.8	52.7	10,050	11,825
	DWDI AF	133	120	209	6	45.1	69.4	51.9	69.8	69.8	52.7	9,925	11,700

\* Unit height shown above includes the standing roof seam.

\* Allow a minimum service clearance of 36" in front of all access doors and air inlet louvers.

\* We recommend a minimum incoming water line pressure of 50 psi. Under no circumstances should the incoming water line pressure exceed 125psi.

\* Standard Evaporative Media access panels require (2) persons to lift on units over 72" high. Consider upgrading to hinged access doors on tall units.

\* Due to continued product development, all data is subject to change without notice. Full details will be provided with submittals.

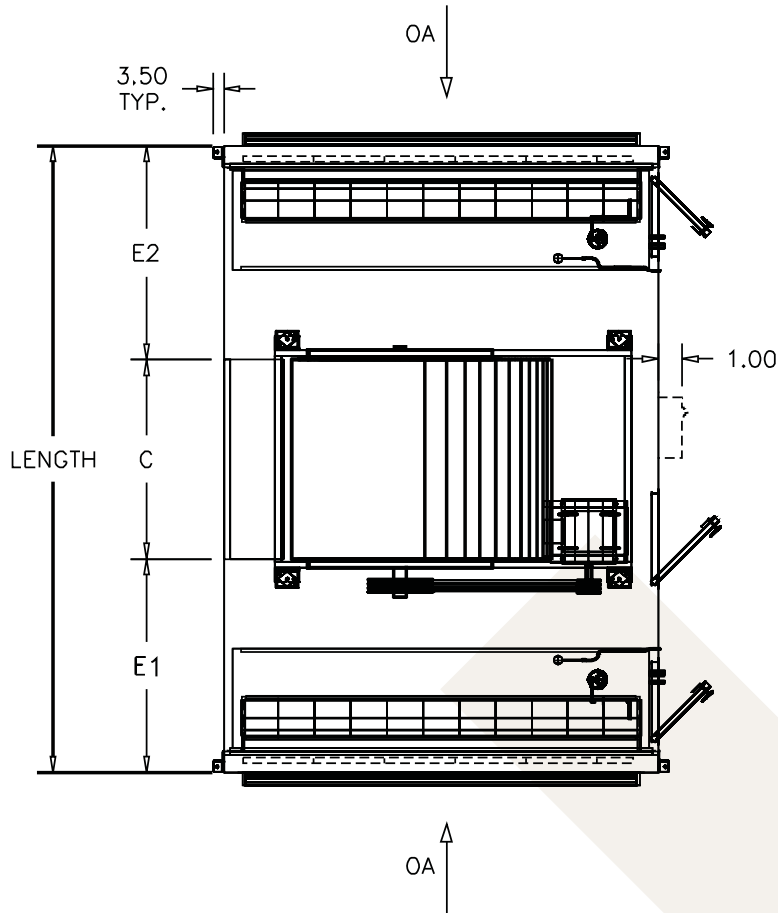

**OUTSIDE CURB DIMENSIONS**

Deduct 5.0" from the O.D. of the baseframe to obtain the O.D. of the roof curb. Please check submittal drawings to verify exact O.D. of the baseframe before the roof curb is built.

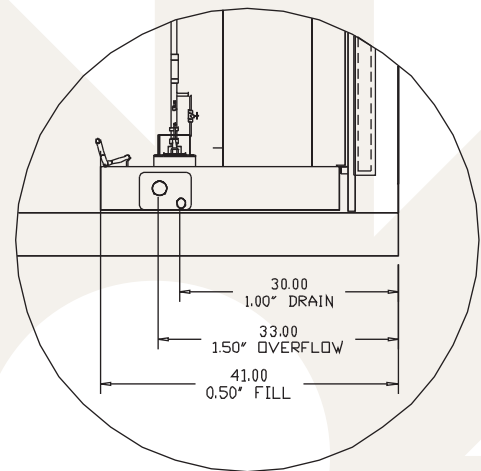
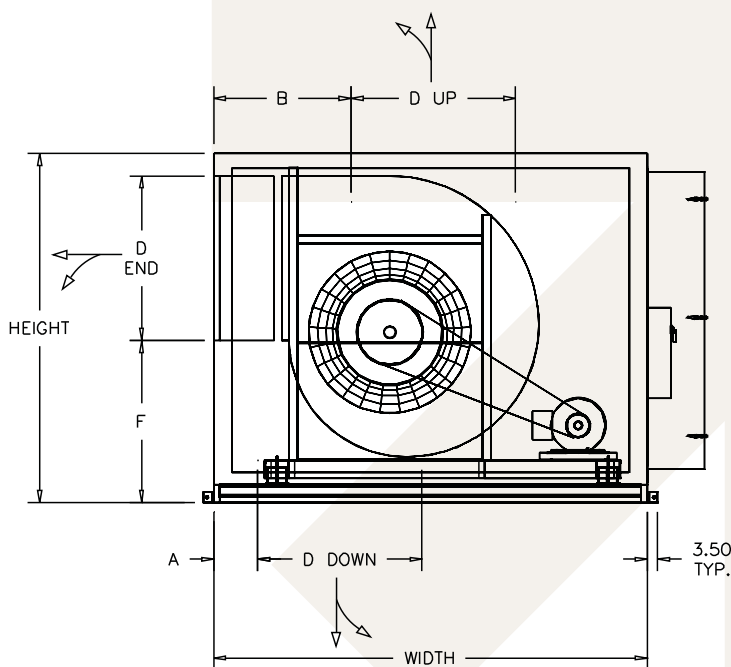

COPPER PLUMBING LOCATION DETAIL