

Commercial / Industrial Evaporative Cooling **16,500 to 22,500 CFM Industry Standard Rating**

Features

- External static pressure range of 0.0" to 1.2" W.G.
- Factory tested and shipped ready to operate, including factory wired components
- ETL listed and labeled in accordance with U.L. standards
- Copper-wound, heavy duty ball bearing motors
- One high capacity pump provides complete media saturation
- Self-aligning, heavy duty, greaseable, pillow block, ball type fan bearings
- Aspen wood fiber media with dust trap filters
- Lifting sky hooks
- Heavy gauge, hot dipped galvanized steel construction
- Epoxy powder base paint finish baked on at 375°
- Rugged cabinet assembly with double thick steel corners
- "Rain-Tight" pitched top construction (1/4"/12")
- Adjustable motor sheave for air flow adjustment

• 400 Series

• UMP-454

- Down Discharge
- Side Discharge

Available Options

- Clean Pump
- Installation accessories
- Fused and non-fused disconnects

Resources Available for This Product

- Catalog By Mail
- Catalog Online



United Metal Products

1920 E Broadway Road Tempe, AZ 85282

T 480.968.9550

F 480.968.9555

www.unitedmetal.com

Model	INDUSTRY STANDARD RATING	HP	AIR DELIVERY IN CUBIC FEET PER MINUTE (CFM)																											
			Inches Static Pressure (W.G.) ①																											
			0.0		0.1		0.2		0.3		0.4		0.5		0.6		0.7		0.8		0.9		1.0		1.1		1.2			
CFM	RPM	CFM	RPM	CFM	RPM	CFM	RPM	CFM	RPM	CFM	RPM	CFM	RPM	CFM	RPM	CFM	RPM	CFM	RPM	CFM	RPM	CFM	RPM	CFM	RPM	CFM	RPM			
UMP-454 Down (D)	16,500	2	13,320	260	12,720	276	12,250	286	11,610	301	11,120	312	10,570	324	9,910	341	9,300	354												
	18,500	3	15,170	300	14,760	309	14,210	322	13,810	331	13,270	344	12,830	354	12,250	367	11,870	376	11,400	388	10,650	405								
	22,500	5	18,060	354	17,570	365	17,230	373	16,750	384	16,470	390	16,020	401	15,740	407	15,300	418	14,940	426	14,470	437	13,620	457	14,140	445	13,140	468		
	24,500	7 1/2	19,400	383	19,400	399	19,400	414	19,400	428	19,180	440	18,950	445	18,540	454	18,290	460	17,920	469	17,490	479	16,790	495	17,240	485	16,520	501		
UMP-454 Side (S)	16,500	2	13,320	260	12,720	276	12,250	286	11,610	301	11,120	312	10,570	324	9,910	341	9,300	354												
	18,500	3	15,170	300	14,760	309	14,210	322	13,810	331	13,270	344	12,830	354	12,250	367	11,870	376	11,400	388	10,650	405								
	22,500	5	18,060	354	17,570	365	17,230	373	16,750	384	16,470	390	16,020	401	15,740	407	15,300	418	14,940	426	14,470	437	13,620	457	14,140	445	13,140	468		

Model	ELECTRICAL SPECIFICATIONS						BLOWER UNIT		EVAPORATIVE MEDIA	WEIGHTS ③	
	Fan Motor ②				Pump		Diameter	Type	Qty. - Width x Height	Shipping	Operate
	HP	Max BHP	Volt/Phase 115/208/230 1-Phase Amps	Volt/Phase 208/230/460 3-Phase Amps	GPH @ 5' HEAD	Volt/Phase 115 1-Phase Amps					
UMP-454 Down(D)	2	2.3	24.0 / 13.2 / 12.0	7.5 / 6.8 / 3.4	380	1.2	25" X 25"	DWDI-FC	8 - 28" X 56"	687	915
	3	3.45	-- / 18.7 / 17.0	10.6 / 9.6 / 4.8	380	1.2	25" X 25"	DWDI-FC	8 - 28" X 56"	702	930
	5	5.75	--	16.7 / 15.2 / 7.6	380	1.2	25" X 25"	DWDI-FC	8 - 28" X 56"	722	950
	7 1/2	8.63	--	24.2 / 22 / 11	380	1.2	25" X 25"	DWDI-FC	8 - 28" X 56"	754	982
UMP-454 Side (S)	2	2.3	24.0 / 13.2 / 12.0	7.5 / 6.8 / 3.4	380	1.2	25" X 25"	DWDI-FC	6 - 28" X 56"	700	928
	3	3.45	-- / 18.7 / 17.0	10.6 / 9.6 / 4.8	380	1.2	25" X 25"	DWDI-FC	6 - 28" X 56"	715	943
	5	5.75	--	16.7 / 15.2 / 7.6	380	1.2	25" X 25"	DWDI-FC	6 - 28" X 56"	735	963

① UMP-400 series, blower type evaporative coolers are designed for ducted applications with external static pressure ranges of 0.0" through 1.2". For straight down ducted low static applications with external static pressure ranges of 0.0" to 0.2" a UMP-500 series propeller type axial fan model may be recommended.

② Only motors 1 HP or less are provided with integral thermal protection. Motors 1.5 HP or greater require a separate motor overload device. Amperage ratings shown are NEC. Usable at 208v. Consult factory for overload and control options.

③ Weights are in pounds and include motors, pumps and drives.

* Performance rating includes the effects of the evaporative media, inlet louver, motor and drives in the airstream.

* Performance shown is for installation Type B; free inlet, ducted outlet.

* Power rating (BHP) does not include drive losses

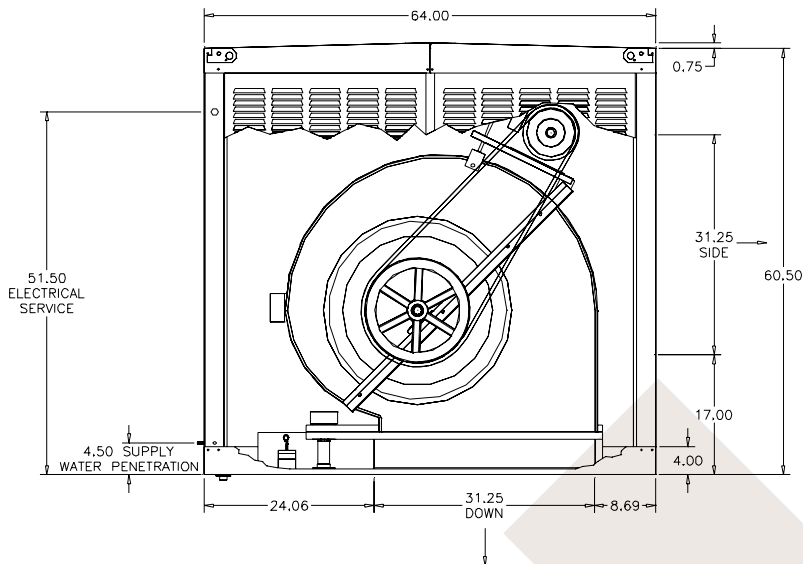
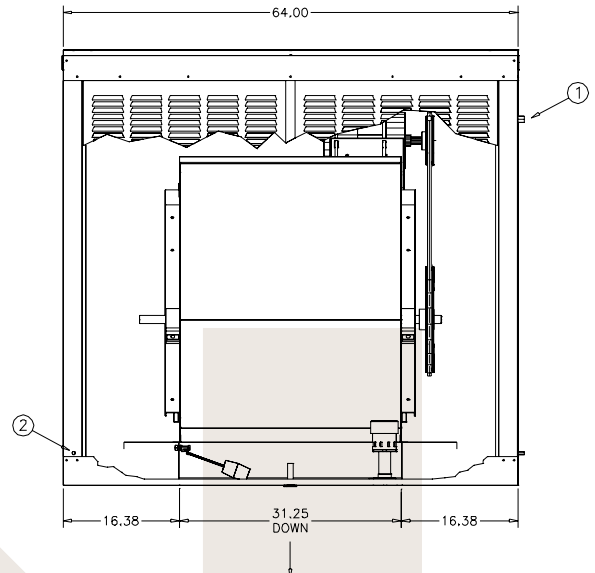
UMP-454
Side View

End View

- ① 7/8" Electrical service entrance for 1/2" conduit.
- ② 3/8" Compression fitting connection made inside unit. Minimum 15 p.s.i. water pressure is recommended to deliver the volume needed to meet high summer evaporation and bleed requirements. Do not exceed 125 p.s.i.
- ③ 3/4" Male hose thread.

Top View
